

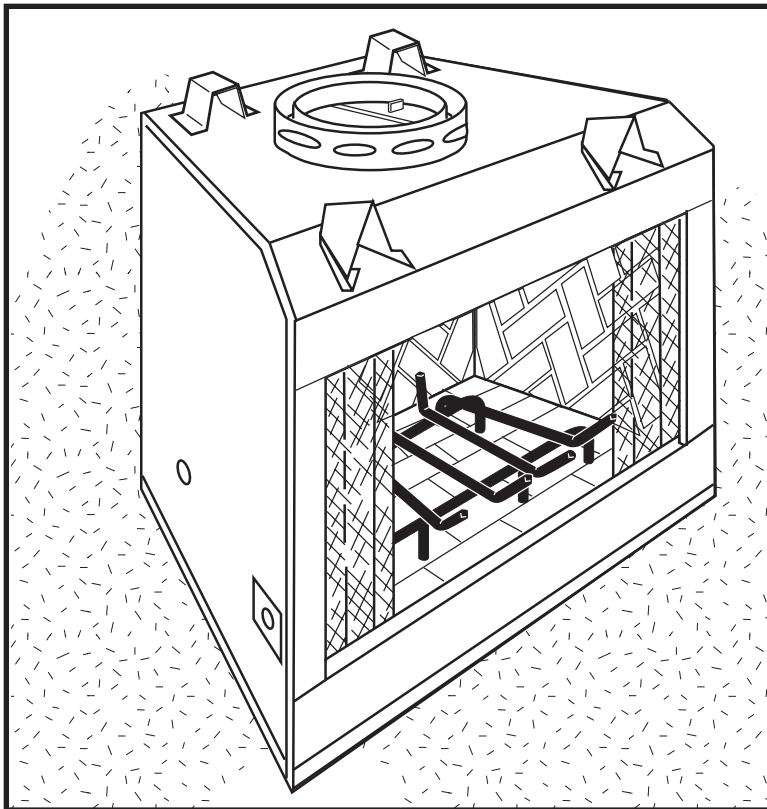

# SHR Series Woodburning Fireplace



Homeowner's Installation  
and Operating Manual

For Models:

**SHR36**  
**SHR42A**  
**SHR48**  
**SHR52**



Underwriter's Laboratories Report No. MH6018

NATIONAL  
FIREPLACE  
INSTITUTE



[www.nficertified.org](http://www.nficertified.org)

We recommend that our woodburning hearth products be installed and serviced by professionals who are certified in the U.S. by the National Fireplace Institute® (NFI) as NFI Woodburning Specialists or who are certified in Canada by Wood Energy Technical Training (WETT).



**DO NOT DISCARD THIS MANUAL: Retain for future use.**

20001384 4/07 Rev. 19

## Safety Information

**PLEASE READ THIS MANUAL BEFORE INSTALLING AND USING FIREPLACE.**

**IMPORTANT:** Read all instructions and warnings carefully before starting installation. Failure to follow these instructions may result in a possible fire hazard and will void the warranty.

### Description

The SHR Series fireplaces are solid fuel, woodburning fireplaces. The SHR36/42A/48 (Super Hearth) are clean-face fireplaces.

### Precautions

CFM Corporation fireplaces and component parts have been highly tested and will operate safely when installed in accordance with instructions provided in this manual. Carefully read and understand all instructions **before** beginning installation.

If you notice any damage to fireplace or component parts, immediately report damage to your Majestic Fireplaces dealer.

Only use CFM Corporation components or the warranty will be voided and a fire hazard may be created.

CFM Corporation warranty will be voided by and CFM Corporation disclaims any responsibility for the following actions:

- **Installation by any other than a qualified installer, preferably NFI or WETT (Canada) certified.**
- **Installation of any damaged fireplace or chimney component;**
- **Modification of fireplace, chimney assembly or any component parts thereof; (except for chase flashings as detailed in the Chimney Top installation instructions).**
- **Installation other than as instructed by CFM Corporation; or**
- **Installation and/or use of any component part not manufactured or approved by CFM Corporation in combination or assembly with a CFM Corporation fireplace system, notwithstanding any independent testing laboratory or other third party approval of such component parts or accessory.**

**Any such action may possibly cause a fire hazard.**

Consult local building codes to ensure that you are in compliance **before** installing the fireplace.

Fireplaces must be vented to the out-of-doors.

**Do not obstruct or modify air inlets/outlets in any manner.**

**Do not install combustible materials on any of the black fireplace surround.**

**Burn only solid wood fuel or gas logs.**

**Do not install a solid fuel burning insert or other products not specified for use with this fireplace.**

**Proposition 65 Warning:** Fuels used in gas, woodburning or oil fired appliances, and the products of combustion of such fuels, contain chemicals known to the State of California to cause cancer, birth defects and other reproductive harm.

California Health & Safety Code Sec. 25249.6

**WARNING: Check with your electronics manufacturer before installing a television or other electronic device above this fireplace.**

### Drafts

The fireplace should not be located in areas that create drafts (ie: frequently opened doors and central heating air inlets/outlets) that hamper the normal flow of air into the fire.

### Gas Logs

If you plan to install a gas log, the gas line should be installed before framing the fireplace. The gas line must be installed by a certified gas line installer.

**SHR36 / SHR42A / SHR48 / SHR52  
Listed**

**UL 127 / ULC-S610  
Standard for Factory Built Fireplaces**

## Table of Contents

Safety Information . . . . .	2
Specifications and Framing . . . . .	3
Parts Identification . . . . .	5
Chimney Requirements . . . . .	6
Planning Information . . . . .	7
Installation . . . . .	8
Replacement Parts . . . . .	20
Accessories . . . . .	21

### SHR36 Series Woodburning Fireplace

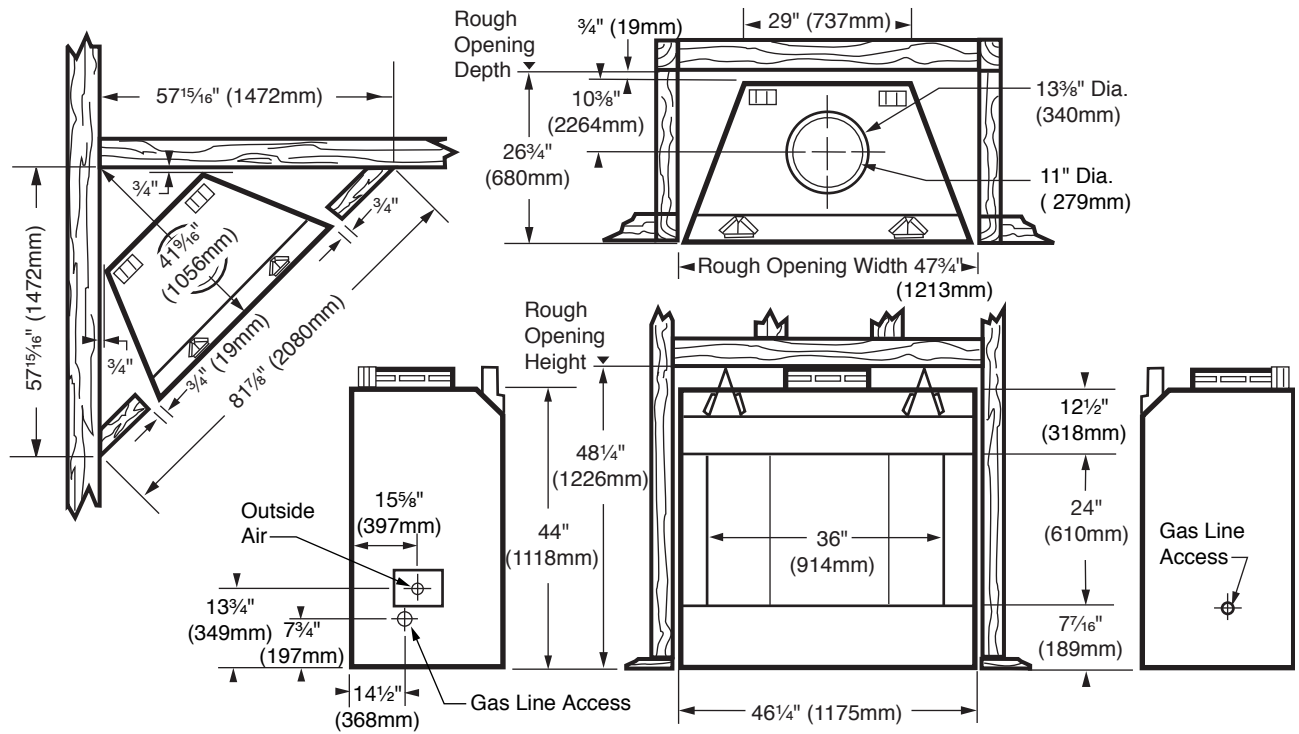

FP526A

Fig. 1 SHR36 Series specifications and framing.

### SHR42A Series Woodburning Fireplace

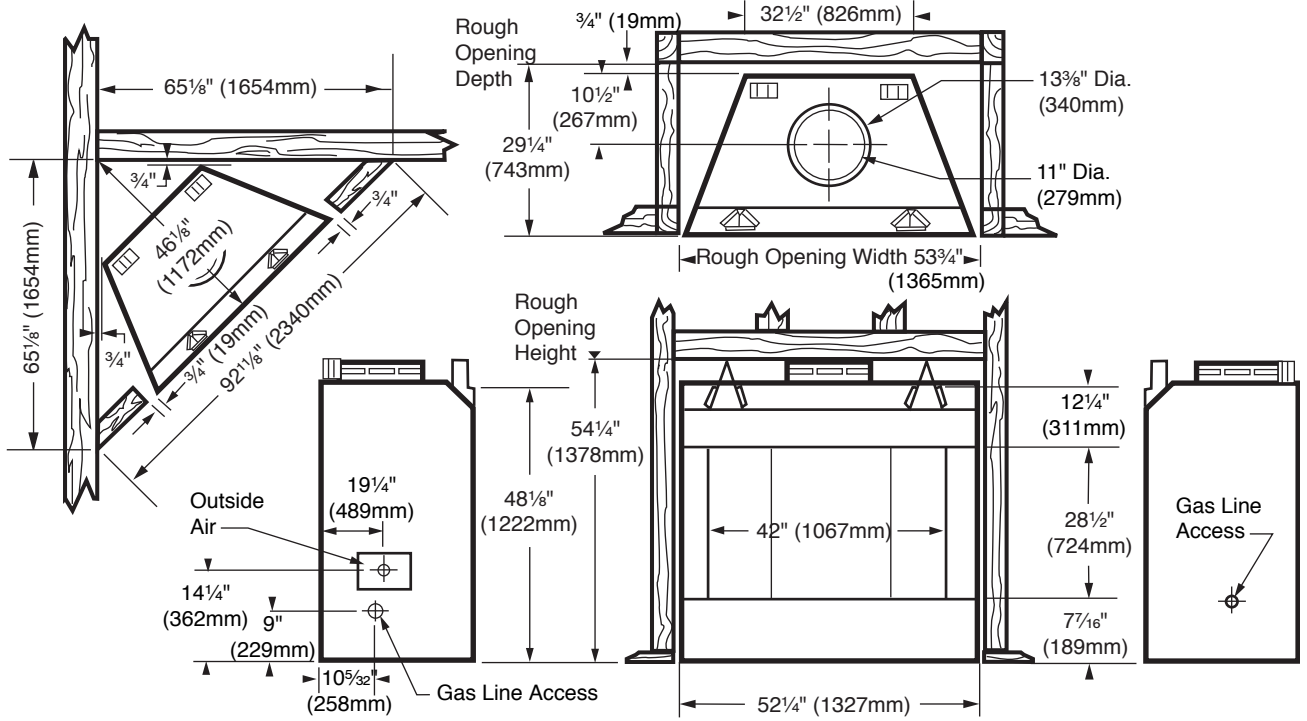

FP546A

Fig. 2 SHR42A Series specifications and framing.

### SHR48 Series Woodburning Fireplace

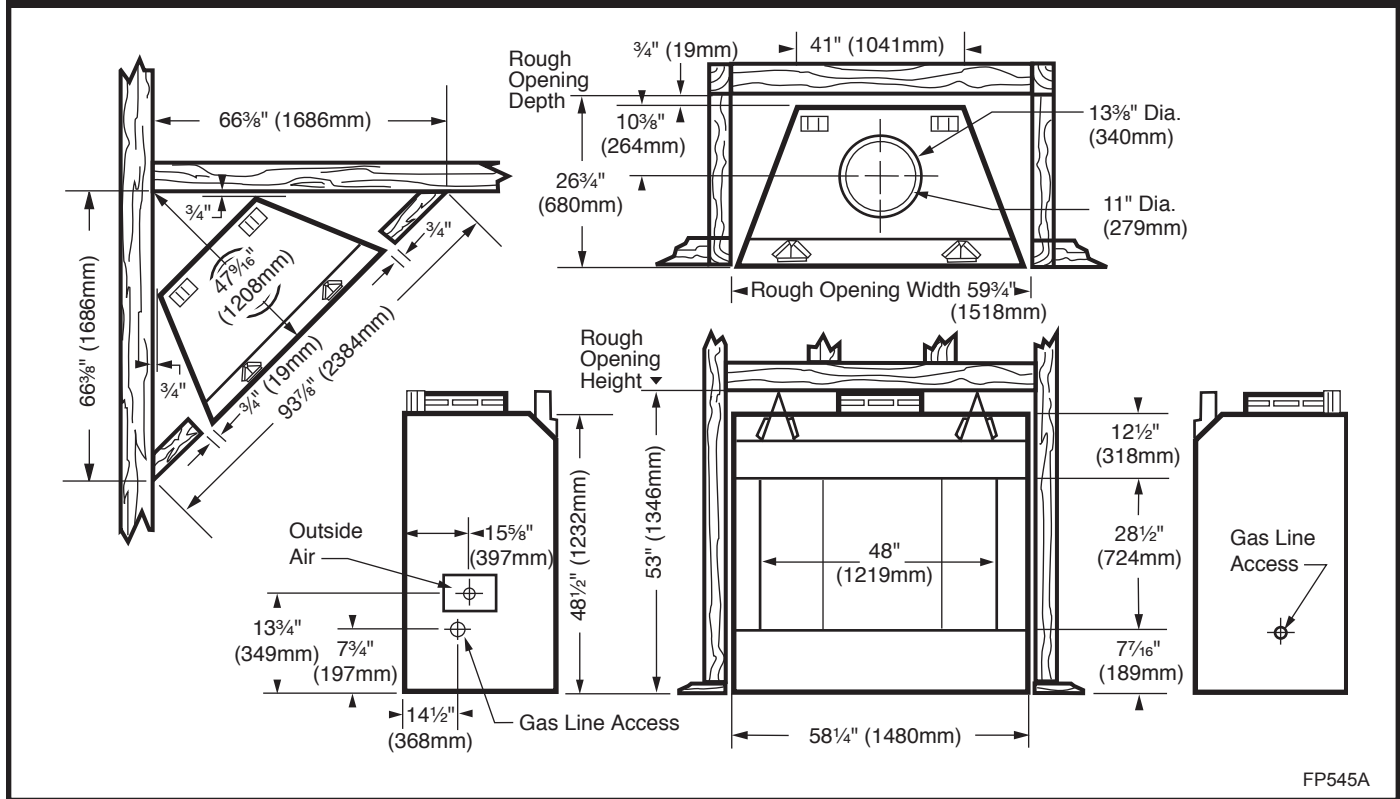

FP545A

### SHR52 Series Woodburning Fireplace

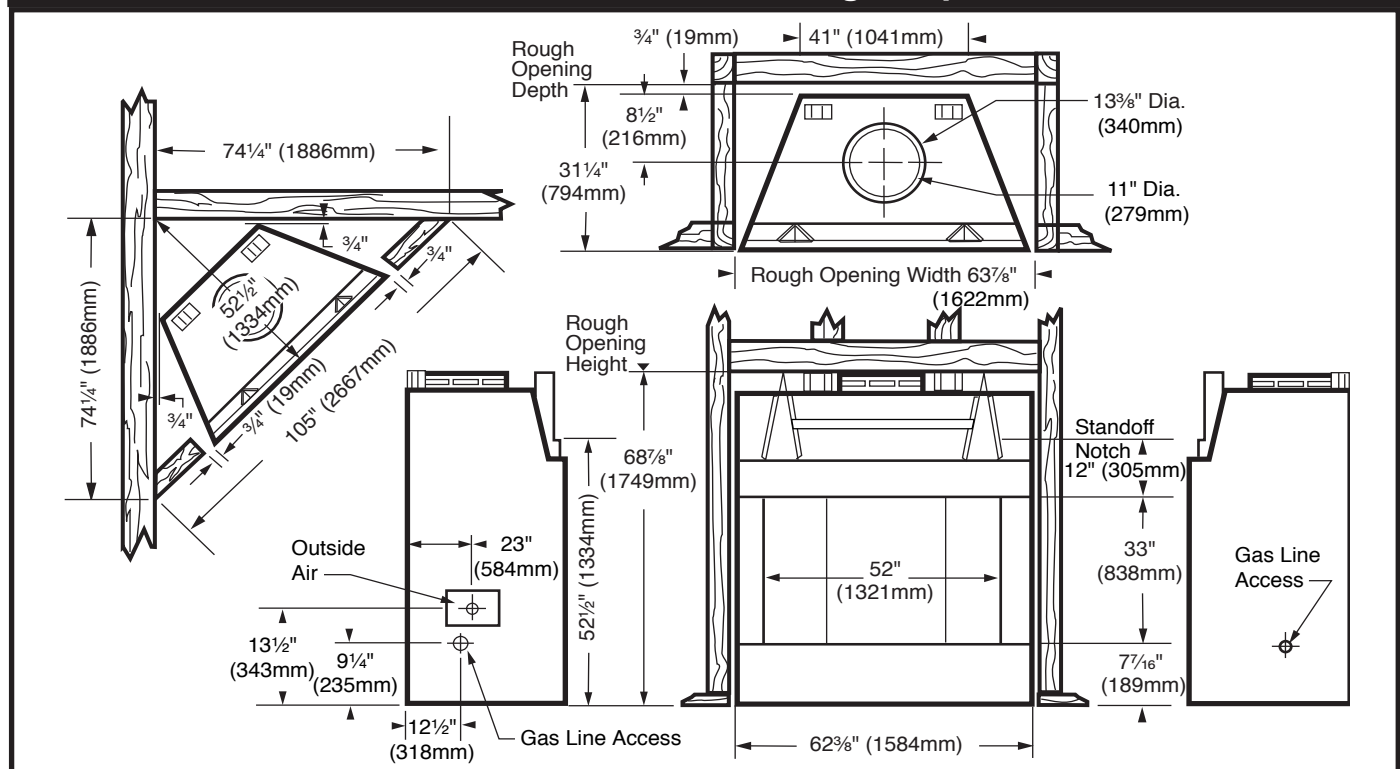

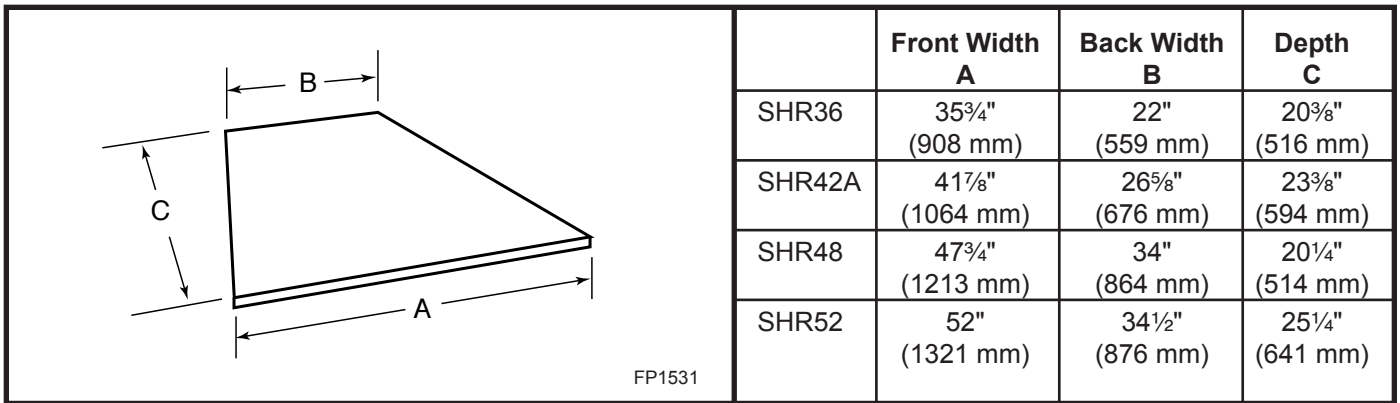

Fig. 4a Hearth dimensions.

### Chase Installation

Insulation methods shown are optional for cold climate, not a requirement for unit operation.

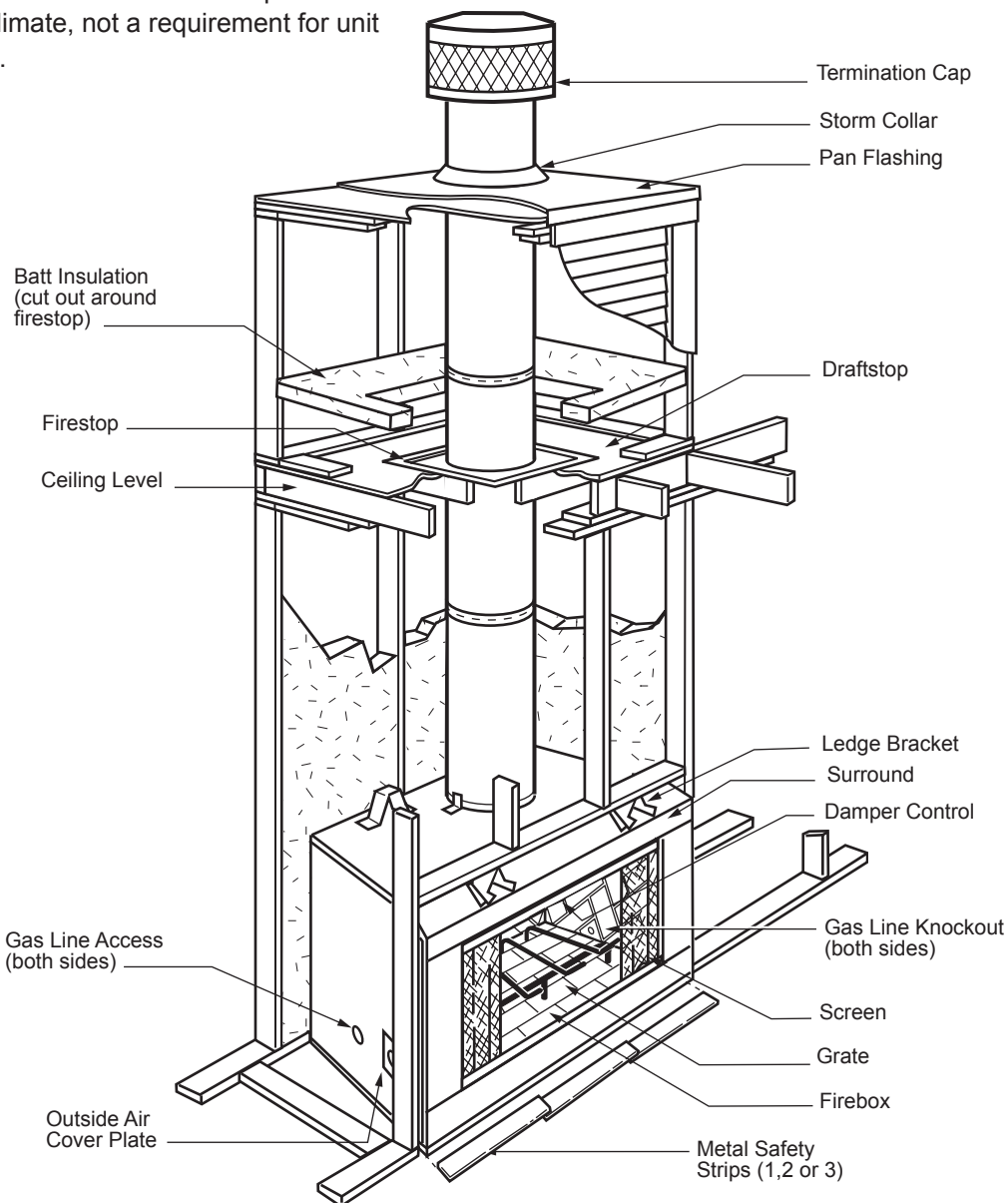
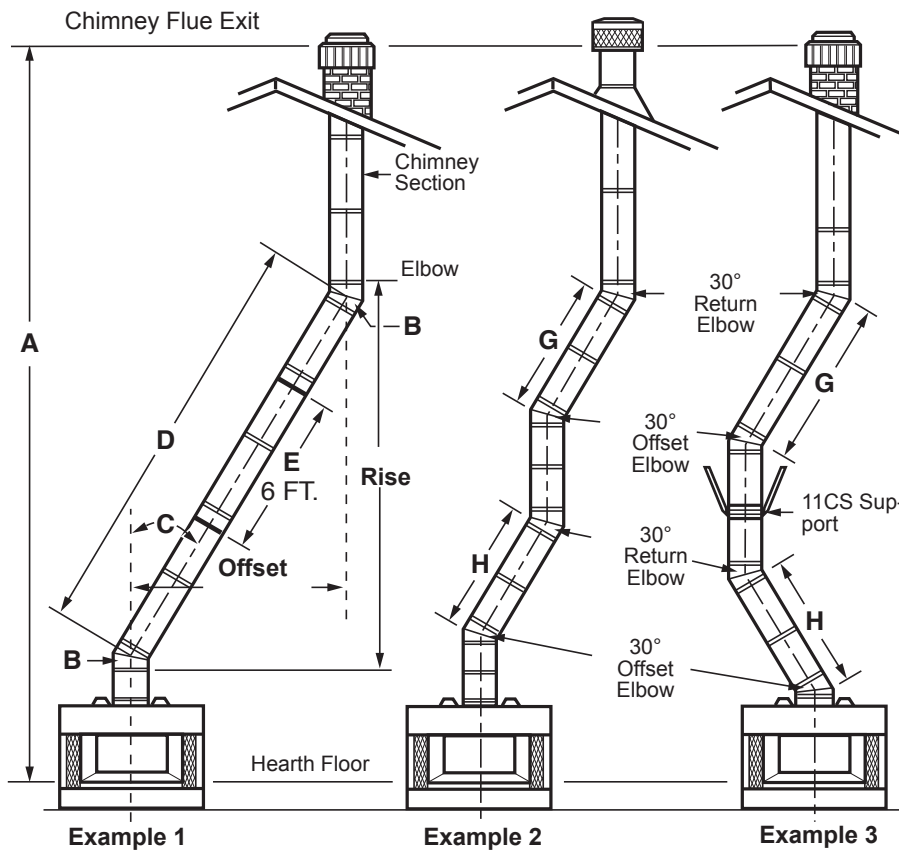

Fig. 5 Fireplace and chase parts identification. (SHR48 shown)

### Chimney Requirements - Offset Installations



**Notes:** G + H cannot exceed 20 feet.  
 \*11CF Chimney airspace clearance = 2" minimum.

FP269

#### Illustration Key

The following safety rules apply to offset installations (letters correspond with illustration above):

**A.** Height of the chimney is measured from the hearth to the chimney exit.

	SHR36	SHR42A	SHR48	SHR52
Max.:	90'	90'	90'	90'
Min.:				
0 Elbows	14'6"	14'6"	16'0"	16'0"
2 Elbows*	15'6"	15'6"	19'0"	19'0"
4 Elbows*	21'0"	21'0"	24'0"	24'0"

**B.** Do not use more than 4 elbows per chimney.

Attach the straps of the return (top) elbow to a structural framing member.

The offset (first) elbow of any pair does not have straps.

**C.** The chimney cannot be more than 30° from the vertical plane in any installation.

**D.** The maximum length of the angled run of the **total** chimney system is 20 feet. (G plus H cannot exceed 20 feet.)

**E.** A chimney support (Model 11CS) is required every 6 feet of angled run of chimney. Chimney supports are required for every 30 feet and 60 feet chimney height above the hearth.

Determine the offset distance of your chimney arrangement from the centerline of the fireplace to the centerline of the chimney where it is to pass through the first ceiling.

**NOTE:** This offset distance may not be your full offset distance. See Examples 2 and 3.

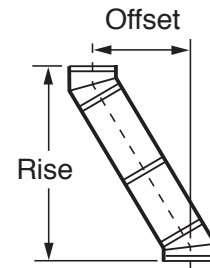

FP282

#### 30° Elbow Offsets

1'	1½'	3'	4'	Chimney Support	Offset	Rise
0	0	0	0	0	3"	11"
1	0	0	0	0	8¼"	20"
0	1	0	0	0	11¼"	25¼"
2	0	0	0	0	13½"	29¼"
1	1	0	0	0	16½"	34¼"
0	0	1	0	0	20¼"	40¾"
2	1	0	0	0	21¾"	43½"
0	0	0	1	0	26¼"	51¼"
0	1	1	0	0	28½"	55¼"
1	0	0	1	0	31½"	60¼"
0	1	0	1	0	34½"	65½"
0	0	2	0	0	37½"	70¾"
1	1	0	1	1	41½"	77¾"
0	0	1	1	1	45"	83¾"
0	1	2	0	1	47¼"	87½"
0	0	0	2	1	51"	94"
0	1	1	1	1	53¼"	98"
0	0	3	0	1	56¼"	103¼"
0	1	0	2	1	59¼"	108½"
0	0	2	1	1	62¼"	113½"
0	1	3	0	1	64½"	117½"
0	0	1	2	1	68¼"	124"
0	1	2	1	1	70½"	128"
0	0	0	3	1	74¼"	134½"
0	1	1	2	2	78"	140¾"
0	0	3	1	2	81"	146"
0	1	0	3	2	84"	151¼"
0	0	2	2	2	87"	156½"
0	1	3	1	2	89¼"	160¼"
0	0	1	3	2	93"	166¾"
0	1	2	2	2	95¼"	170¾"
0	0	0	4	2	99¼"	177¾"
0	1	1	3	2	101¼"	181¾"
0	0	3	2	2	104¼"	186¼"
0	1	0	4	2	107¼"	191½"
0	0	2	3	2	110¼"	196¾"
0	1	3	2	3	114"	203¼"
0	0	1	4	3	117¾"	209¾"
0	1	2	3	3	120"	213½"
0	0	0	5	3	123¾"	220"

Fig. 6 Chimney system requirements.

## Planning Information

Preplanning an installation is very important to ensure safety and to save time and money. An installer must predetermine where a fireplace will be set and how the chimney system will be run.

### Mounting the Fireplace

A fireplace may only be mounted on the following surfaces:

1. A flat combustible surface.
2. A raised wooden platform.
3. A concrete block or other solid object placed beneath each of the four (4) corners of the fireplace.

The fireplace **must** be spaced 3/4 inch from a combustible back wall and 3/4 inch from a combustible side wall or support. (Fig. 20, Page 14)

### Planning the Chimney Run

Determine how the chimney will be run, length of run and chimney components required to complete the job. (Fig. 6) **Never** install a chimney below minimum heights.

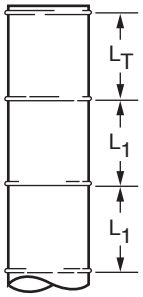
	11CF Chimney Model No.	Total Length (L <sub>T</sub> )	Installed Length (L <sub>1</sub> )
	11CF1	11½"	10½"
	11CF18	17½"	16½"
	11CF3	35½"	34½"
	11CF4	47½"	46½"

FP288b

Fig. 7 Installed lengths of chimney sections.

In planning a chimney system, it is important to know:

1. The height of a chimney is measured from the hearth to the exit point on the termination.
2. A chimney cannot be offset more than 30 degrees from a vertical plane.
3. A chimney may run straight up or it may be necessary to offset it to avoid obstructions.
4. The maximum length of an angled run (total chimney system) is 20 feet.
5. No more than 2 offsets (4 total 30° elbows in) per fireplace may be used.
6. A guy wire stabilizer is required for chimneys extending more than 6 feet above a roof line.

### The Ten Foot Rule

Major U.S. building codes specify a minimum chimney height above the roof top. The "Ten Foot Rule" is a fire safety rule and not a draft rule. To ensure proper draft, it is recommended that you always meet or exceed the "Ten Foot Rule," especially when installing a termination on a high pitch roof. (Fig. 8)

The key points of the "Ten Foot Rule" are:

1. If the horizontal distance from the chimney to the peak of the roof is 10' (3m) or less, the top of the chimney must be at least 2' (610mm) above the peak of the roof, but never less than 3' (914mm) in height above the highest point where it passes through the roof.
2. If a horizontal distance from the chimney to the peak of the roof is more than 10' (3m), a chimney height reference point is established that is on the surface of the roof a distance of 10' (3m) from the chimney in a horizontal plane. The top of the chimney must be at least 2' (610mm) above the reference point, but never less than 3' (914mm) in height above the highest point where it passes through the roof.

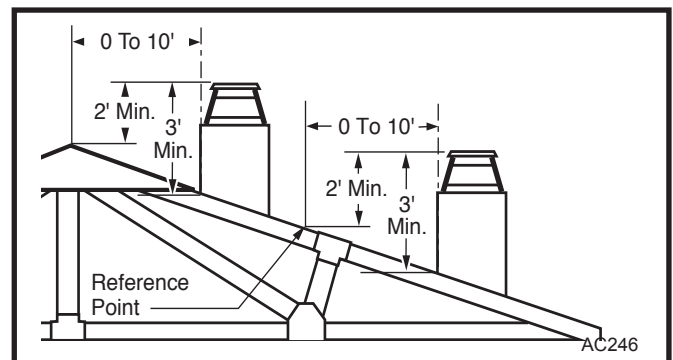

Fig. 8 Ten Foot Rule illustration.

## Chimney Supports

The chimney system is supported by the fireplace for vertical chimney heights less than 30 feet above the hearth. Chimney supports are required if the vertical height exceeds 30 feet with 11CF chimneys. Locate chimney supports at ceiling holes or other structural framing at 30 foot heights. Spacing between chimney supports **must not** exceed 30 feet. Use Chimney Support Model 11CS. **(NOTE: The 11CS can not be mounted directly to the fireplace.)** Support provided by elbow straps fulfills the support requirement only if they are spaced as previously described. (A chimney support is 2½" long when installed.)

Angled chimney runs require a support every six (6) feet in addition to the elbow straps. Chimney supports are used for this function. (Fig. 9)

## Chase Installation

A chase is a vertical boxlike structure which encloses the fireplace and/or chimney. Chases are typically built on the outside of the house with fireplace opening cut into the outer wall of a room. (Page 5, Fig. 5)

If you need help in determining fireplace location or how the chimney system should be run, contact your Majestic Fireplaces dealer for assistance.

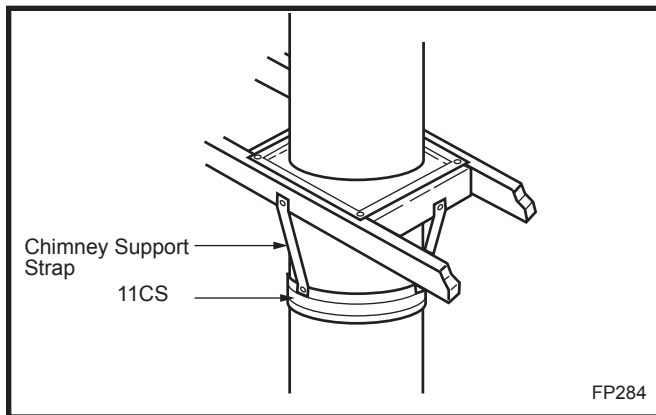

Fig. 9 Chimney support installation

## Installation

### Insulating Fireplace Enclosure for Cold Climates

If you live in a cold climate, it is not required but **highly recommended** that you insulate the fireplace enclosure to eliminate cold air penetration as much as possible.

Insulate base of fireplace with a noncombustible insulation rated for a minimum of 300° F. Insulating is **very important** for outside wall installations over a concrete slab. If fireplace is installed on a platform, insulation should be placed on top of the platform **before** fireplace is set. (Fig. 10)

When a fireplace is installed in a chase or on an outside wall, enclosure should be treated like any outside wall in a home. Insulation should be installed on the inside wall as well as the outside wall(s). In a chase, it is also a good idea to install a firestop at the first ceiling level above the fireplace and enclose the chase with sheeting material. Insulation may then be installed above sheeting material to assure the space around the fireplace is totally protected. (Fig. 5)

**CAUTION: WHEN INSTALLING A FIREPLACE IN AN INSULATED ENCLOSURE, BE SURE ALL REQUIRED AIR SPACES ARE MAINTAINED.** (Page 15, Fig. 19)



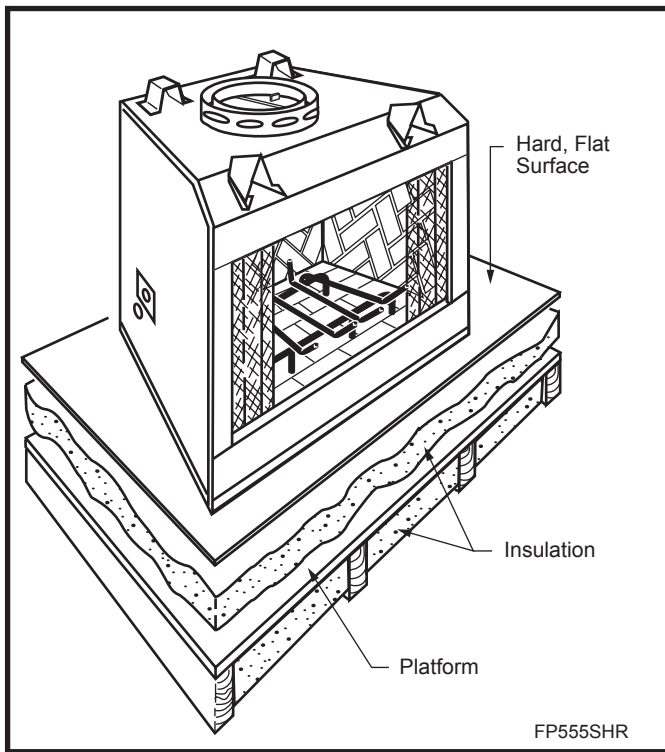

Fig. 10 Insulating between platform and fireplace.

### Framing

Framing can be constructed before or after the fireplace is set in place, however, most installers build the frame before setting the fireplace.

Frame fireplace with 2 x 4 lumber or heavier materials. Refer to framing dimensions in Figures 1 - 4 for basic fireplace specifications.

**NOTE:** Framing should be positioned to accommodate wall covering and fireplace facing material.

### Firebrick Installation

For the SHR52 model the firebrick is packed separately and must be installed in the fireplace.

You will need four (4) firebrick, three (3) brick retainers, a phillips head screwdriver, and the grate.

The side and rear firebrick each have a notch in the top of the brick panel. The side firebrick have a notch in the lower front side of each panel. The herringbone pattern faces out of the fireplace always. (Fig. 11)

**NOTE:** The screens and screen rod smoke baffle assembly must be removed and set aside before proceeding. Remove the two screws holding the screens place. There are seven screws holding the screen rod smoke baffle in place.

1. Remove the three brick retainers from the combustion dome by removing the phillips screws, set aside.
2. Set the left firebrick in place on the left side of the fireplace.

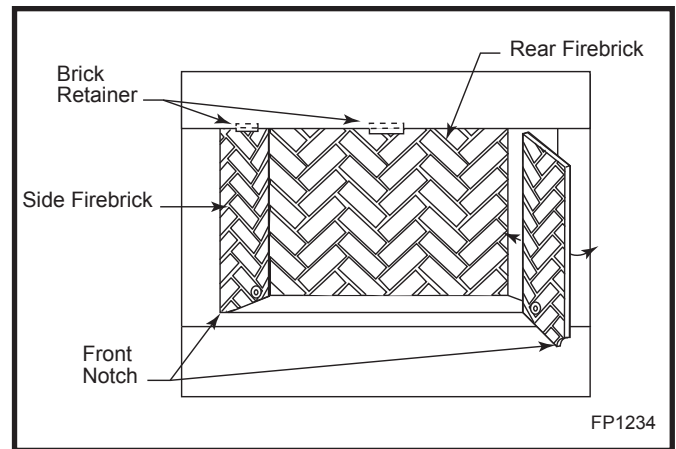

Fig. 11 SHR52 Firebrick installation.

3. Slide the rear firebrick back into the left corner behind the end of the left firebrick. Push both panels back as far as possible into the left side and corner.
4. Swing the right side of the back firebrick into place. Attach the left brick in place using a brick retainer at the top and phillips screw removed earlier.
5. Slide the right firebrick into place as far back as possible. Attach rear firebrick and right firebrick using brick retainers and phillips screws removed earlier.
6. Slide the hearth firebrick into the grate clip. (Fig. 12) The grate will be used as a handle to set the hearth firebrick in place.
7. With the hearth firebrick securely in place in the grate clip, carefully lift the hearth firebrick into the fireplace, set the rear of the firebrick down, then slide back to meet the rear firebrick. Gently set the front of the firebrick in place. Replace screens and screen rod smoke baffle assembly.

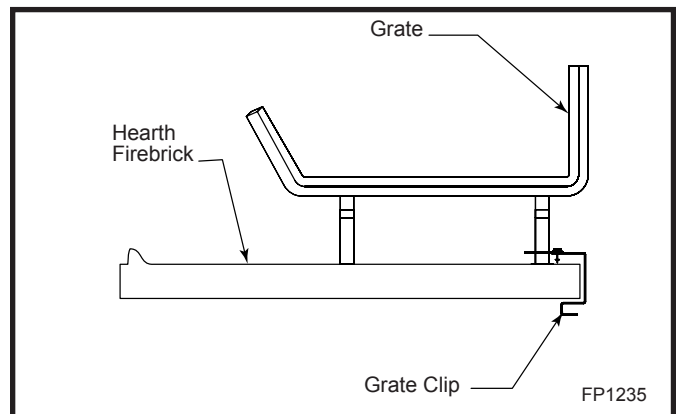

Fig. 12 Hearth firebrick in place in grate clip.

### Chimney Set-up

Since you have already preplanned the chimney run, you should know exactly how the installation is to be accomplished — how much pipe is required, the number of elbows, if any, and type of termination to be used.

**CAUTION:** REPORT TO YOUR DEALER ANY PARTS DAMAGED IN SHIPMENT, SPECIFICALLY CHECK THE END CONNECTION OF CHIMNEY SECTIONS AND ELBOWS.

**NOTE:** SHR Series Fireplaces must use CFM Corporation model 11CF, 11 inch, 2 wall chimney systems. The installation procedure described in this manual applies **only** to the 11CF system, chimney components may not be mixed.

**Straight-Up Chimney Installation**

To mark the centerline of the flue, put the fireplace in final position and measure out from the wall 11 1/8". Mark a spot on the ceiling directly above the fireplace. Draw a line parallel to the back wall through this mark. (Fig. 13)

Using a plumb bob positioned directly over center point of fireplace flue collar, mark the ceiling to establish the chimney center point. (Fig. 13)

**Offset Installation**

In order to clear an obstruction, it may be necessary to offset chimney from vertical. This is accomplished by using CFM Corporation elbows. Use the 30° Offset Elbow table on Page 6 to determine proper offset and parts required.

Each offset requires two (2) elbows. The second elbow is equipped with support straps. It is very important to install the second elbow in each offset as close to the ceiling or support as possible so the elbow straps can be secured to framing members to help support the weight of the chimney.

Determine offset distance of your chimney arrangement from centerline of fireplace to centerline of chimney where it is to pass through ceiling.

Locate center point of the chimney on ceiling as though a straight up chimney arrangement is to be used. Measure your offset dimension from straight up chimney center point on ceiling.

**Ceiling Chimney Hole/  
Possible Obstructions**

The size of the hole in ceiling will vary with the angle at which the chimney passes through ceiling.

Drive a nail up through ceiling at marked chimney center point. Go to floor above and see where hole will be cut. Check to see where existing ceiling joists and other possible obstructions are located...i.e. wiring, plumbing etc... If necessary, reposition chimney and/or fireplace to avoid obstructions.

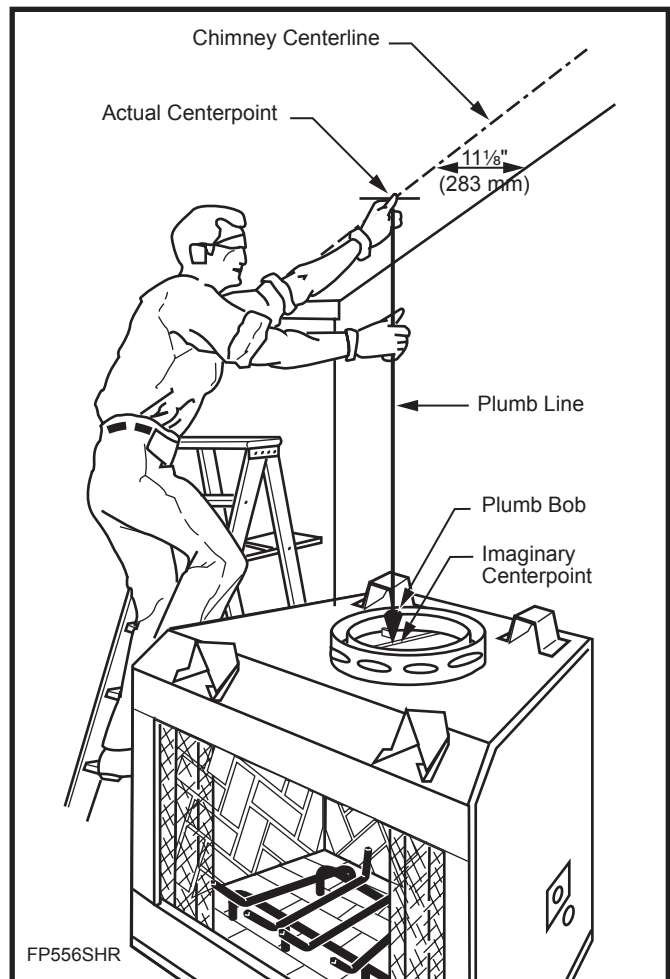

Fig. 13 Locate centerline of chimney with plumb line.

**Cutting the Hole**

Cover fireplace collar opening and cut proper sized chimney hole in chimney. (Fig. 14 & 15)

**Framing the Ceiling Hole**

Frame the ceiling chimney hole as shown in Figure 15. It is good practice to use framing lumber that is the same size as the ceiling joists; this is a requirement at attic level.

The following table gives firestop spacer model numbers:

**CHIMNEY HOLE SIZE**

Size of Chimney	Angle of Chimney at Ceiling	
	Vertical	30°
11" CF 2-Wall	FS2A 17 1/2" x 17 1/2" (445 x 445 mm)	FS6A 17 7/8" x 29 5/8" (454 x 753 mm)

Fig. 14 Ceiling chimney hole size necessary for installing firestop spacer.

The **inside dimension** of the frame **must be** the same as the hole size selected from Figure 11 in order to provide the required 2 inches of air space between the outside diameter of the chimney and the edges of the framed ceiling hole.

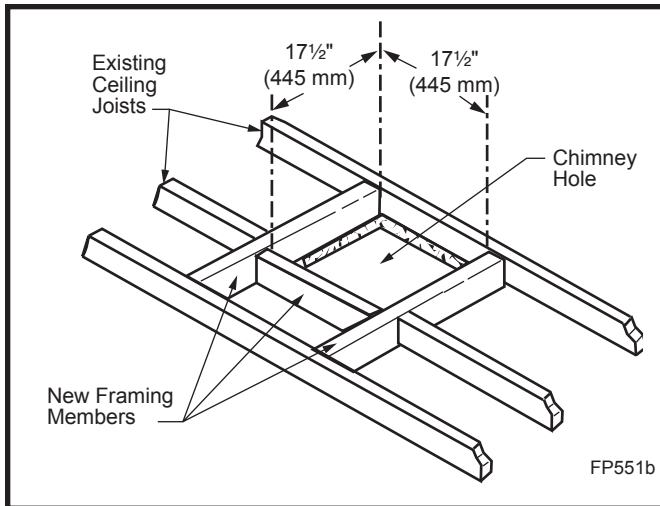

Fig. 15 Typical frame for ceiling chimney hole

### Positioning, Safety Strips, Securing the Fireplace

Slide fireplace into position.

Lift the fireplace front slightly and slide the metal safety strips under front bottom edge about 1½ inches, allowing the remainder to extend in front of firebox. Overlap strips at least 1/2 inch to provide a positive joint. (Flat safety strips are packed with fireplace.) (Fig. 16)

Safety strips are used to ensure that any combustible materials in front of the fireplace are protected even though a noncombustible hearth extension is required.

If fireplace is to be elevated above the floor, a "Z" shaped metal safety strip must be fabricated and used to protect combustible surfaces in front of the fireplace. This "Z" shaped safety strip is not provided but must be fabricated of metal with each horizontal leg at least 1½ inches wide and equal in length to the metal strips provided with the fireplace.

**NOTE:** Safety strips are not required over noncombustible floors where all supports at the base of the fireplace are noncombustible.

Four (4) nailing flanges are supplied with the fireplace (found on the fireplace hearth). To level the box and secure it firmly in place, remove the nailing flanges from the hearth and install at the sides of the fireplace as shown in Figure 17.

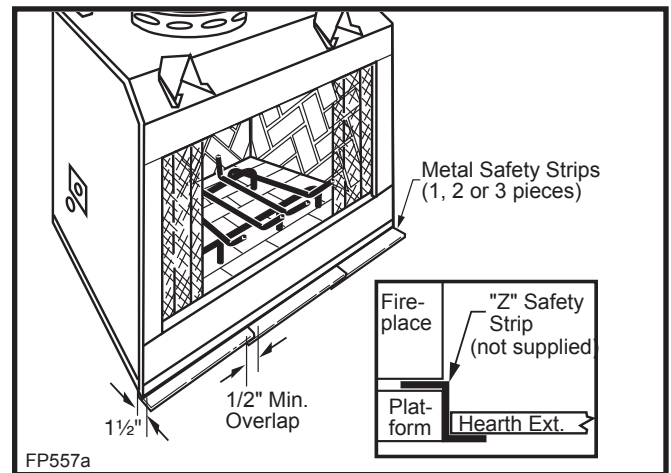

Fig. 16 Safety strip installation.

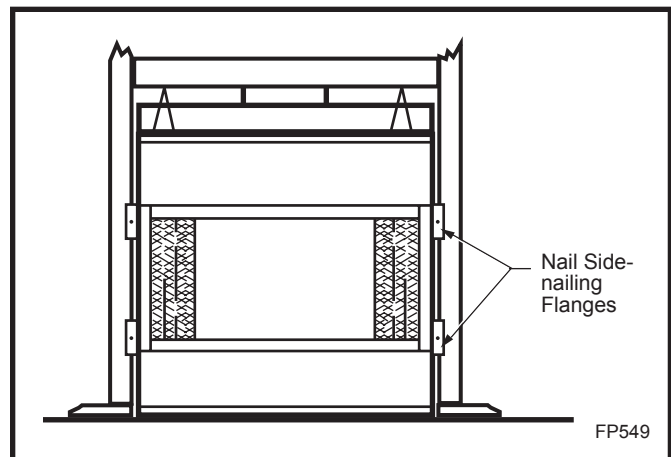

Fig. 17 Fasten fireplace in position.

### Installing Outside Air Kit

An outside air damper assembly is installed in all SHR Series Fireplaces. If desired, or if local codes mandate the use of an air kit, then an AK-MST is required to complete the installation (from air damper assembly to the outdoors). If the outside air kit is to be used, the AK-MST **MUST** be installed **BEFORE** the fireplace is enclosed. Refer to the AK-MST instructions for field installation. The outside air control lever is located in the center, just above the left side brick. To 'open', push control lever up and back. To 'close', pull lever forward and down. (Fig. 18)

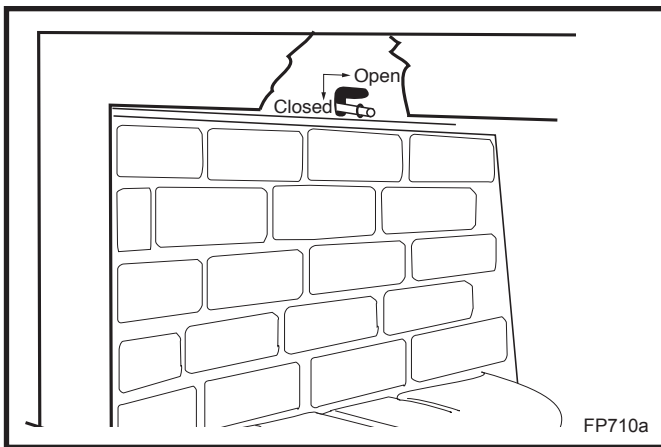

Fig. 18 Outside air operation.

### Installing the Chimney System

Start by attaching the first chimney section to the collar on top of the fireplace.

Install the pipe as pictured in Figure 19. When you get a good lock, you will hear the pipe clearly snap together. Once sections are snap-locked in place, it is extremely difficult to get them apart. **Make sure the pipe is firmly snapped and locked together as each pipe section is mounted.**

When installing elbows, only outer pipe will snap-lock. Middle pipes simply slide into position. Be sure to always attach straps on upper elbow to a structural framing member. (Fig. 20)

Continue installing the pipe as required until pipe is installed up through the ceiling. At this point, you must install a firestop spacer.

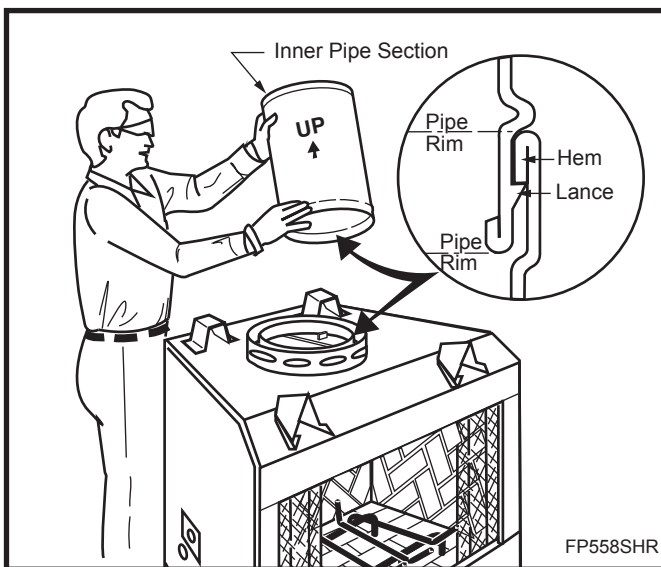

Fig. 19 Install pipe, listening for the snap-lock to fasten.

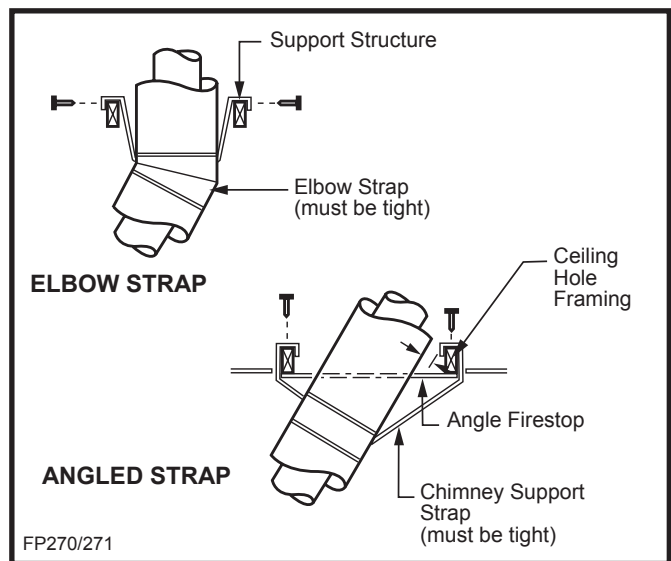

Fig. 20 Attach straps to a structural framing member.

### Installing the Firestop Spacer in the Ceiling Hole

A firestop spacer is used to keep pipe spaced properly and required for safety.

Nail the firestop spacer (at each corner) to the framing members of the ceiling hole. **Note:** A firestop spacer is not required at the roof.

Hole sizes listed in Figure 14 for angled firestop spacers provide minimum required air space to chimney pipe for ceiling thickness up to eight (8) inches. When combined thickness of ceiling material, ceiling joists and flooring material exceeds eight (8) inches, adjustments must be made in framing to assure that minimum air spaces to chimney are maintained.

### Proper Firestop Spacer Installation

Figure 21 shows different installation procedures for both an area that is an attic and an area that is not an attic.

If the area above the ceiling is **not** an attic, position the firestop spacer with the flange on the ceiling side and the angled portion extending up into the hole.

If the area above the ceiling is an attic, position the firestop spacer with the flange on the top of the framed hole and the angled portion extending down into the hole.

Firestop spacers are not available for, nor are they required on, vertical walls.

The chimney components (CF11) used on the SHR series fireplaces have been tested and approved with the area where the outer pipe slides through the firestop spacer sealed with a noncombustible caulk if desired, or left completely open with no sealant. This sealing only applies to the SHR series fireplace.

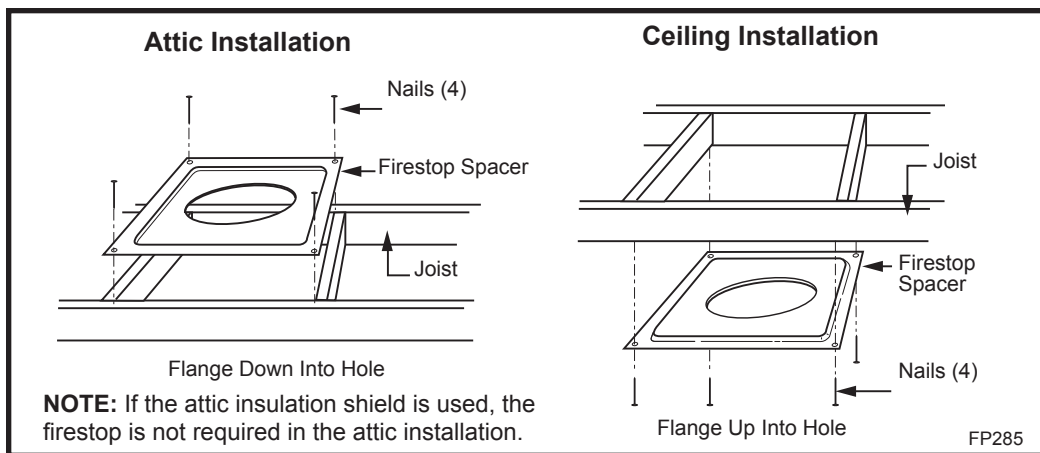

Fig. 21 Installing firestop spacer.

### Canadian Requirements for Insulation Shield

In Canada, an attic insulation shield is required to prevent attic insulation from contacting the chimney section. **NOTE:** If the attic insulation shield is used, the firestop is not required in the attic installation. Framing dimensions for the chimney hole should measure 17½" x 17½" (445 x 445 mm). An attic shield **MUST** be installed on top of attic joists (above the floor level). (Fig. 22)

**NOTE:** In the U.S., it is a good idea, although not always required, to install an attic insulation shield where blown-in insulation is planned to be used in the attic.

Install the attic insulation shield with the flanges on its base extending down into the framing hole. Nail each corner of attic insulation shield to the framing members of the ceiling hole using 8d nails. Attic shields are not required at the roof.

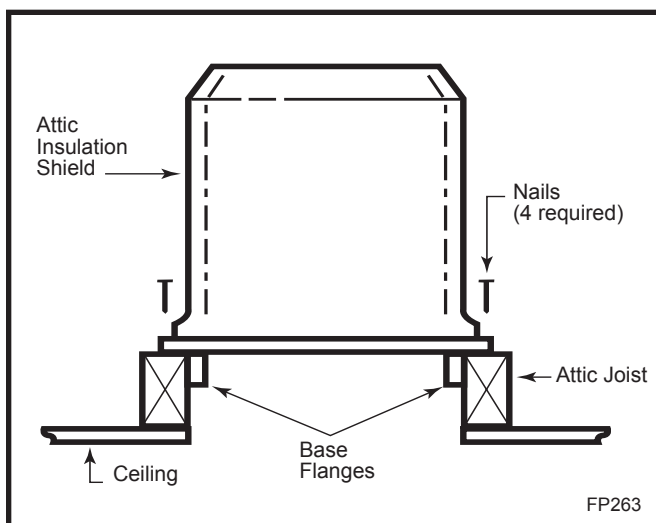

Fig. 22 Attic shield installation (Canadian requirement).

### Continue Installing Pipe to Complete Run

Continue attaching pipe sections to complete system to next level always being careful that the pipe is firmly snap locked in place before proceeding to next pipe section.

### Chimney Supports

If chimney supports are required, they are installed the same as elbows. Nail chimney support straps to adjacent structural framing, as shown in Figure 8, Page 8. Bend straps as necessary and make sure they are secure so they will support the weight of the chimney. A chimney support is 2½" long when installed. Consider this dimension when determining how many straight chimney sections are needed.

**NOTE:** Chimney supports are generally used in long runs in a chase installation.

### Additional Ceilings

If you encounter additional ceilings, repeat same steps required for first ceiling installation. Refer to firestop illustration in Figure 21.

### Penetrating the Roof

Run pipe to roofline. Since chimney system must be vented to the out-of-doors, you **must** use an approved termination.

If a chase is used, refer to the installation manual provided with the termination cap.

### Locate Chimney Centerpoint on Roof

Use same procedure detailed in locating center point of the flue system.

Drive a nail up through roof at the center point. This will determine center point on outside of the roof.

### Cut and Frame Roof Hole

Size of roof hole varies with the type of chimney termination installed. Refer to installation instructions provided with the chimney termination to find correct size roof hole.

There must be a 2" (51 mm) air space between outermost portion of chimney sections and any adjacent combustible surfaces. (Combustible surfaces include burnable materials such as: ceiling members, joists, flooring, combustible insulation and roof structures.)

**WARNING: DO NOT PACK REQUIRED AIR SPACES WITH INSULATION OR OTHER MATERIALS.**

Mark an outline of the roof hole around the centerpoint of the nail. **NOTE:** Hole dimensions given in the chimney top installation instructions are **horizontal** dimensions; therefore, the hole size must be marked on the roof accordingly.

Cover the opening of the installed chimney so debris cannot get into the system.

Cut and frame the hole. It is good practice to use framing lumber that is the same size as the rafters. Install the frame securely because the chimney top and flashing anchored to the frame must be able to withstand heavy winds.

### Install Remainder of Chimney Sections

Since you have already preplanned the height of your termination according to the *Ten Foot Rule*, continue to install pipe to the predetermined height.

Check the chimney top installation instructions for details on how high above the roof top the chimney sections (all pipes) should extend.

### Installing Top Housing or Termination

Follow the installation instructions provided with the chimney termination you have selected.

### Installing Chimney in a Chase

Refer to Page 5, Figure 4 for an illustration of a typical chase installation.

**CAUTION:** Treatment of firestop spacers and construction of chase may vary with type of building. These instructions are not a substitute for local building codes. You **must** check your local building codes to determine specific requirements for your city or state. **NOTE:** Other building materials may be required in addition to Firestop Spacers.

### Finishing

**CAUTION:** All joints between the finished wall and the fireplace surround (top/sides) must be sealed with noncombustible material to prevent cold air leakage into

the room. Only noncombustible material may be applied to the facing of the fireplace surround. (Black painted area) (Fig. 23)

The SHR52 has a framing shield between the front standoffs that may be used to attach finish material. (Fig. 25)

### Finish Wall

Finish the wall with material of your choice. **Do not install a combustible mantel shelf less than 12" (305 mm) from the top of the fireplace opening. Do not install a mantel face plate less than 6" (159 mm) from top of fireplace opening.** (Fig. 29) If a combustible material is used below a flat mantel shelf, consult your local building codes for minimum clearance from top of fireplace opening to bottom of mantel shelf.

All joints (top, bottom and sides) where wall or decorative facing material meets fireplace surround must be completely sealed with a noncombustible material. (Figs. 24-29)

**NOTE:** No side wall protection is required for fireplaces installed at 45° to two (2) side walls (corner installation).

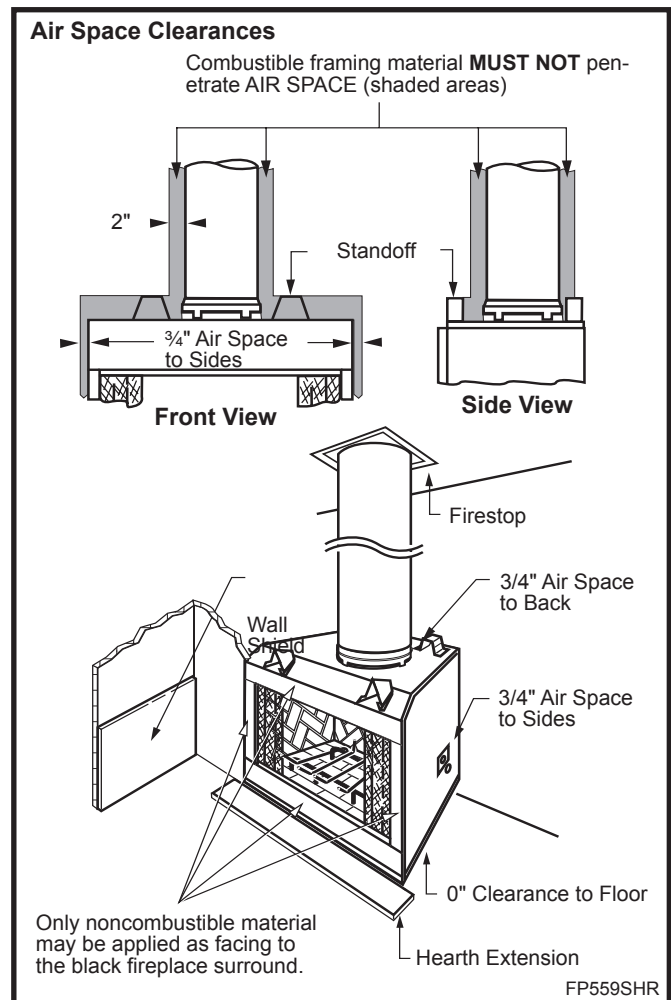

Fig. 23 Minimum clearances to combustibles.

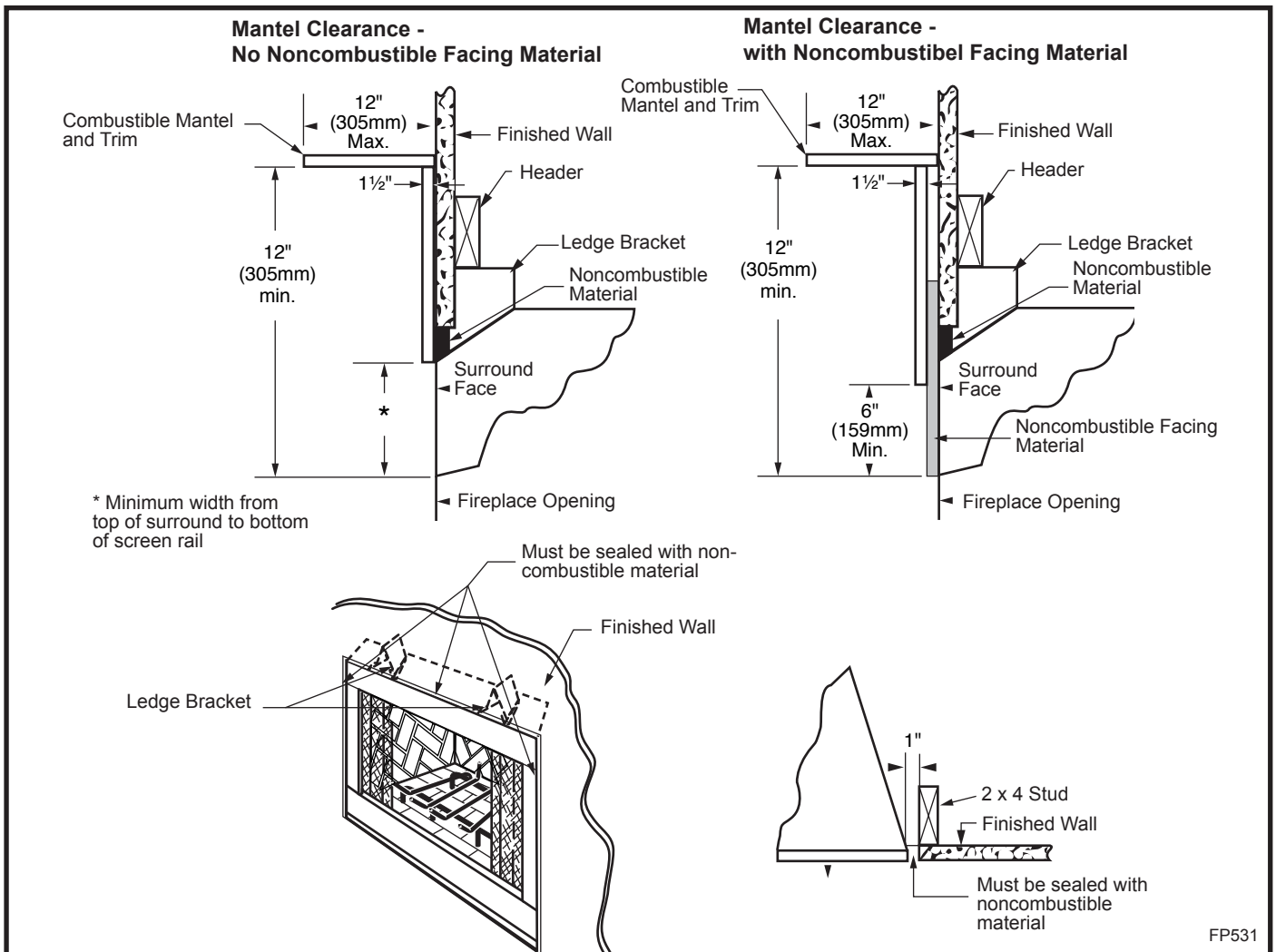

Fig. 24 Mantel clearance.

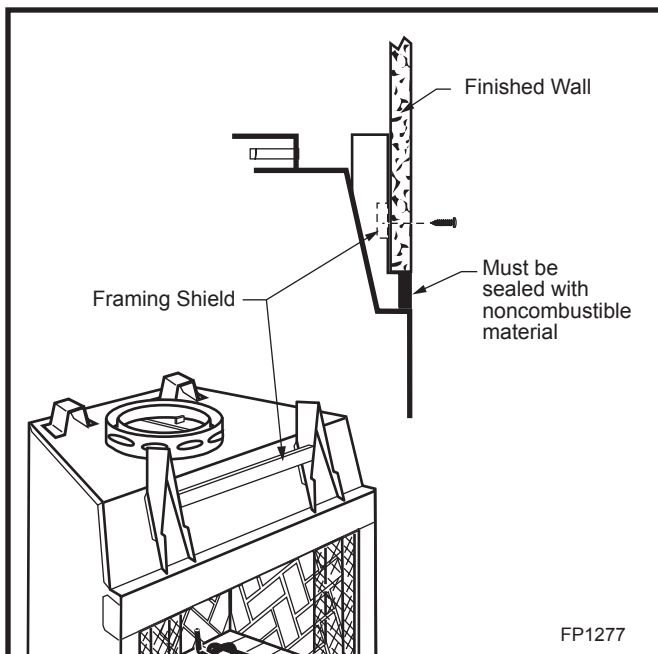

Fig. 25 SHR52 framing shield may be used to attach finish material.

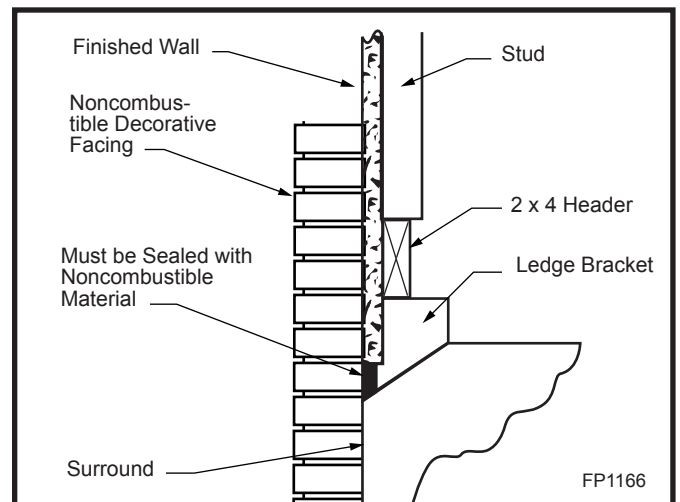

Fig. 26 Fireplace surround flush with finished wall.

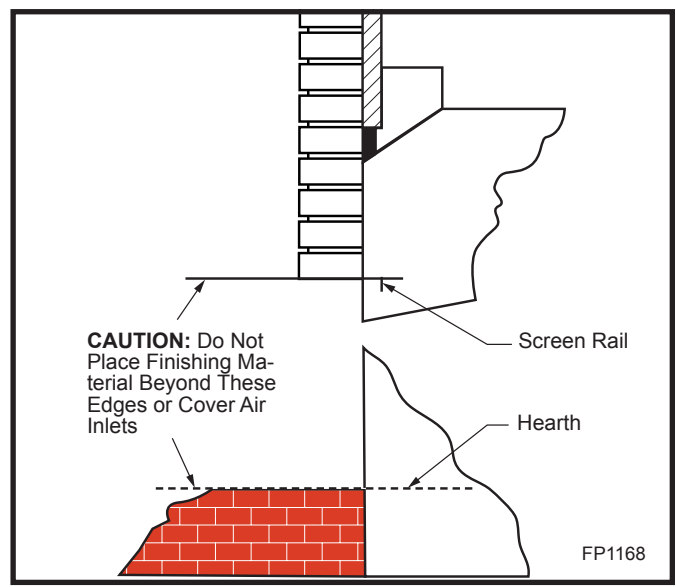
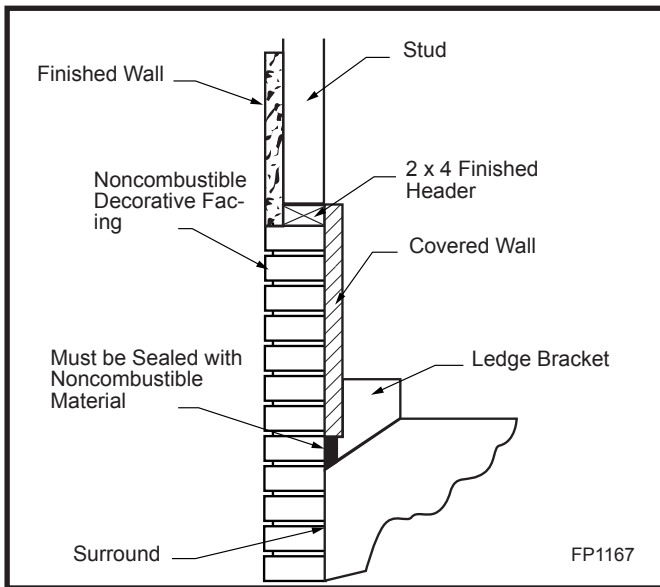
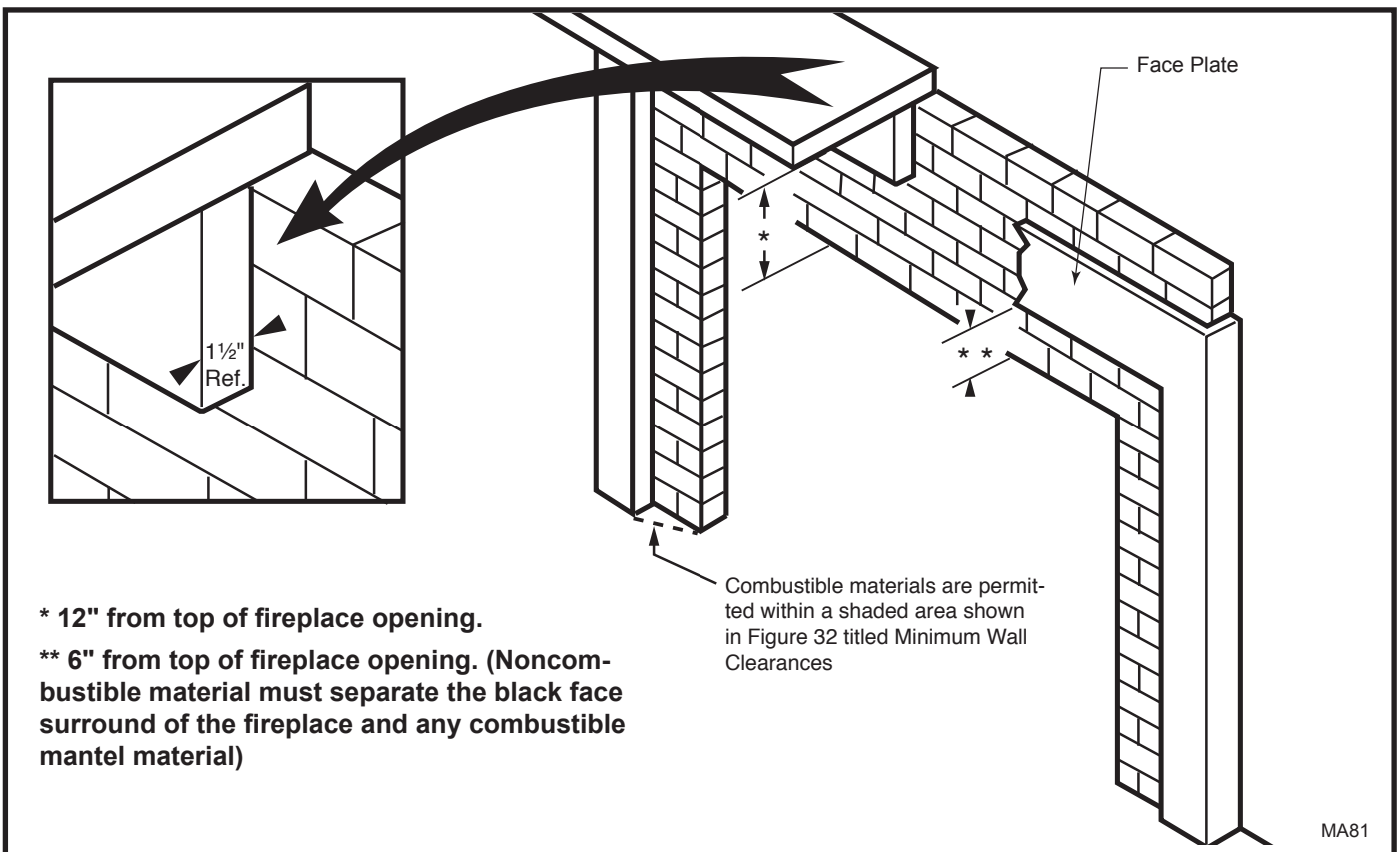

Fig. 27 Facing on fireplace surround flush with finished wall.

Fig. 28 Finishing front of fireplace.



\* 12" from top of fireplace opening.

\*\* 6" from top of fireplace opening. (Noncombustible material must separate the black face surround of the fireplace and any combustible mantel material)

Combustible materials are permitted within a shaded area shown in Figure 32 titled Minimum Wall Clearances

Fig. 29 Combustible mantel clearances.



### Side Wall Protection

Adjacent combustible side walls that are within dimensions shown in Figure 30 of fireplace opening must be protected with Wall Shield Model SP40 or a specifically built wall shield described in Figure 29.

The special wall shield design described in Figure 27 is an alternate method of adding protection to side walls and can be used in place of the SP40 with the same wall clearances specified for the SP40. Rt must = 1.85 minimum.

**Examples of wall shield insulation:**

1. Manville - CERAFORM 126, K=.27, 1/2 inches thick
2. CFM Corporation - EH2416, K = .458, 1 inch thick required.

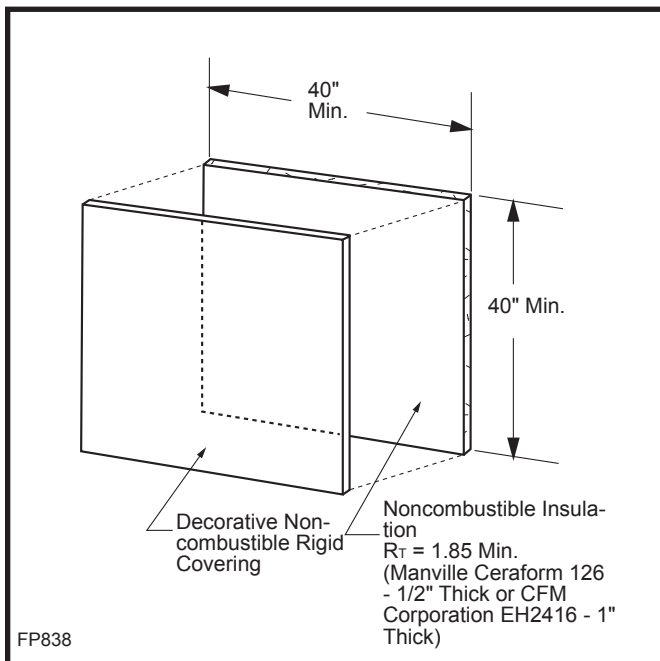

Fig. 30 Noncombustible wall shield dimensions.

### Hearth Installation

A hearth extension is required to protect a combustible floor in front of the fireplace. Refer to Figure 30 for minimum dimensions and mounting detail.

**NOTE: Hearth Extension must not cover the air inlet opening of a fireplace.**

The hearth extension described in Figure 32 must be a durable noncombustible material with a minimum (total) Rt value of 1.09; refer to Figure 31 for examples. The overall height (above a combustible floor), depth and width must be as indicated, with the extension centered to the fireplace opening.

The top of insulation must be covered with a noncombustible decorative covering or a piece of .018" minimum sheet metal, to protect hearth extension material. (Fig. 32)

Secure the hearth extension to the floor to prevent shifting, using trim molding or other similar means at three (3) outer edges. Seal crack between the fireplace hearth and hearth extension with a noncombustible material. (Figs. 32-35)

**WARNING: HEARTH EXTENSION MUST BE INSTALLED IN ACCORDANCE WITH FIGURE 26.**

Alternate noncombustible materials may be used providing the (total) thermal resistance (Rt value) of the alternate material employed is greater than or equal to R = 1.09. Thermal resistance (R) or thermal conductivity (K), may be obtained from manufacturer of the material. Factors are related by the formula  $K = 1/R$ . (Fig. 31)

T = given thickness

R = thermal resistance for a given thickness (T)

K = thermal conductivity

Noncombustible material with a lower R value may be used, provided thickness of material is sufficiently greater to maintain an equivalent (total) thermal resistance (Rt).

### Example of Determining Hearth Extension Equivalents

To determine the thickness required for any new material:

$$\text{NEW thickness required} = \frac{\text{K of new material (per inch)}}{\text{K of listed material (per inch)}} \times \text{thickness of listed material}$$

### Example for Common Brick

$$T (\text{new}) = 5.0 / 0.458 \times 0.50 \text{ in.} = \mathbf{5.46 \text{ in.}}$$
 (new required thickness).

### Common Materials And Factors

Material	K*	R	Minimum Thickness
EH2416 (CFM Corporation)	0.458	1.09	0.50 in.**
Common Brick	5.0	0.10	5.46 in.**

R Value is for 1/2 inch.  
 \* Units of K = BTU/SQ FT/HR°F/IN  
 \*\* Thickness of Listed Material

FP533ADD

Fig. 31 Hearth extension material factors.

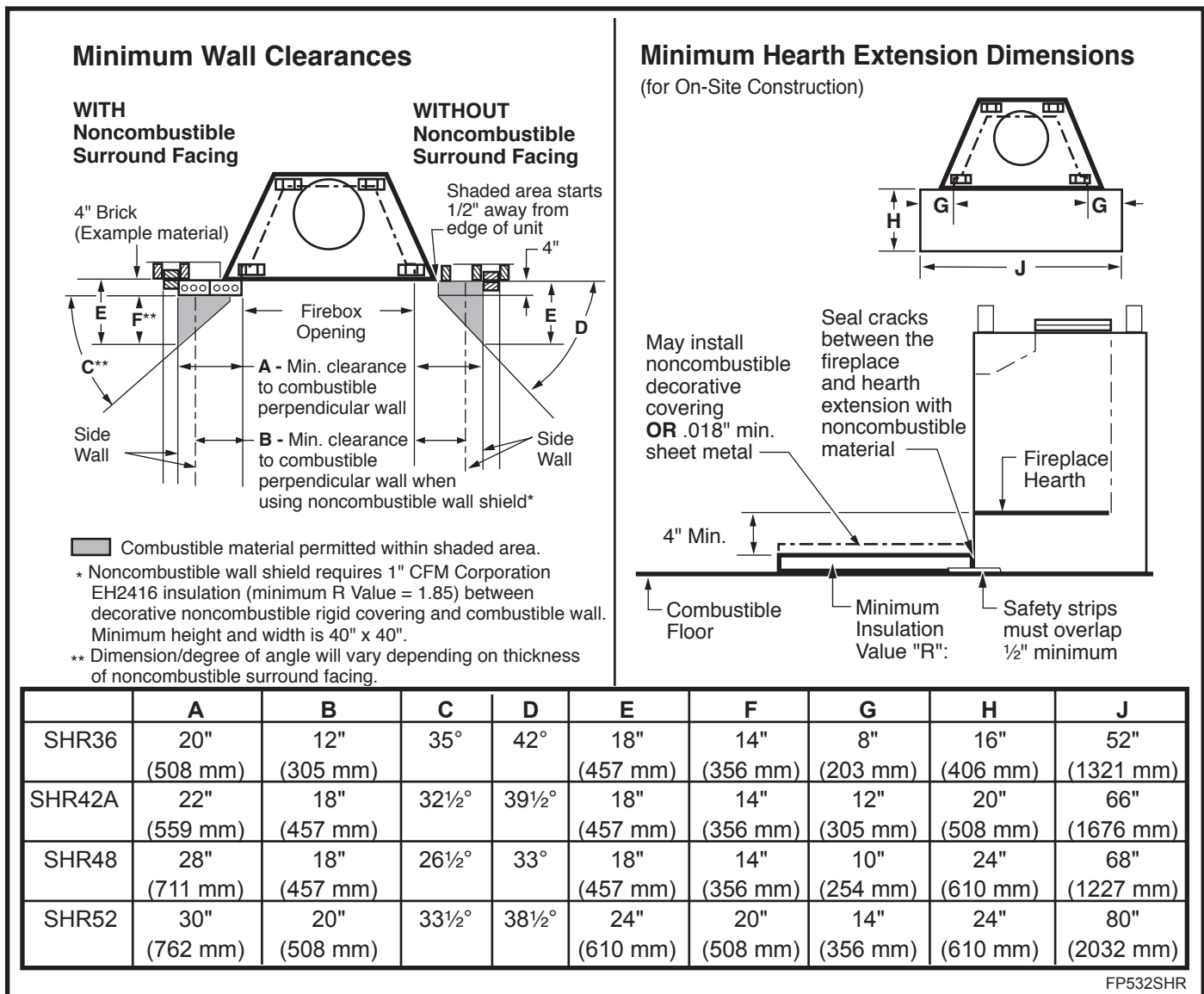

Fig. 32 Combustible side wall protection and hearth extension dimensions.

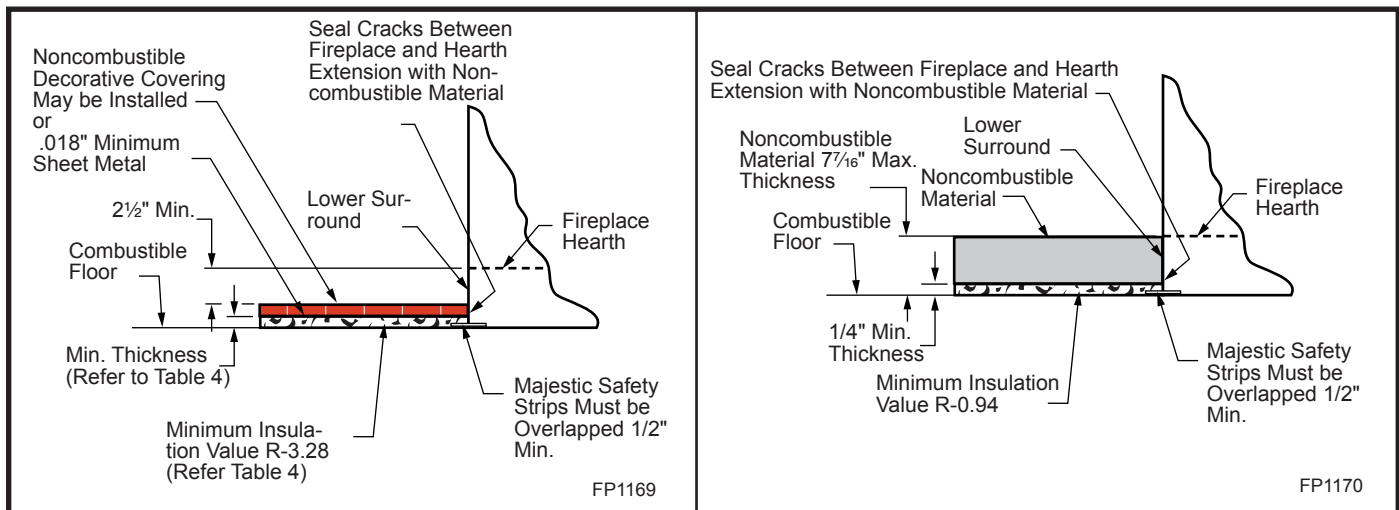

Fig. 33 Protection of adjacent combustible side walls and hearth extension dimensions.

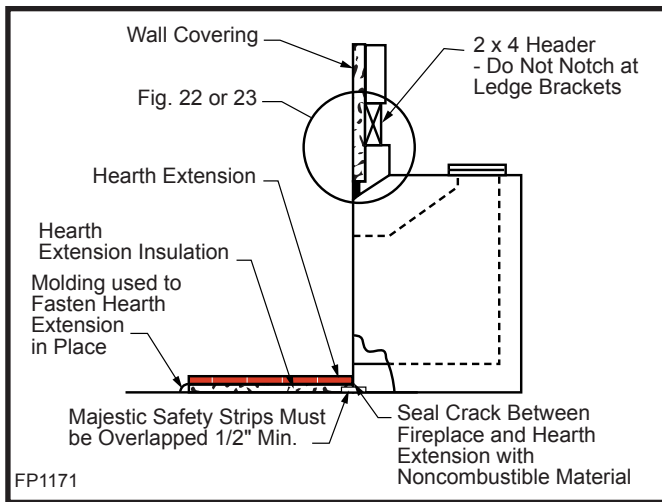

Fig. 34 Sealing detail.

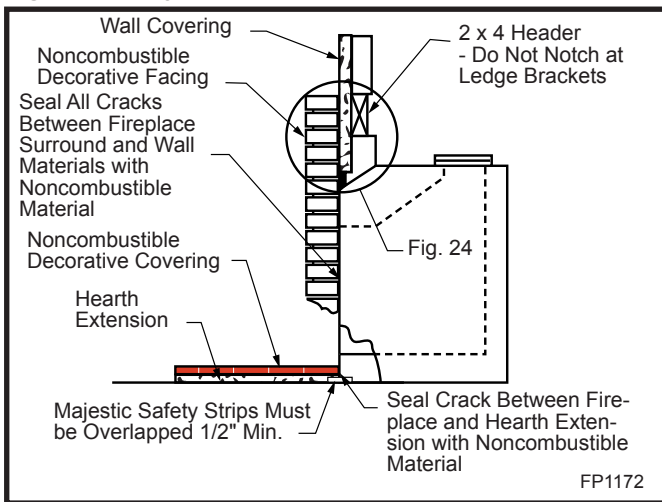

Fig. 35 Sealing detail.

### Installing Line for Gas Logs

CFM Corporation fireplaces are designed to accept a 1/2 inch gas line for installation of an approved gas appliance. (CFM Corporation manufactures a wide variety of gas logs for use in CFM Corporation fireplaces.)

Be sure to have the appliance installed in accordance with building codes.

Gas connection may enter from either left or right side of the fireplace.

Locate appropriate gas line in the outer casing of fireplace and remove insulation from gas line tube. (Fig. 36) From inside the fireplace, locate the knockout on the firebrick -- be sure you are on the appropriate or "gas line" side of the fireplace. Using a flat bladed screwdriver or small chisel and hammer, carefully tap around the knockout until it loosens and falls out.

Install 1/2 inch certified gas pipe through opening. After gas pipe installation is complete, use insulation that was

removed from gas line tube to repack space around the pipe. Material should be inserted from outside of the fireplace and packed tightly to totally seal between the pipe and tube.

**NOTE: Gas pipe should not come in contact with any wood structures until it has reached a point at least one (1) inch away from fireplace side.**

**NOTE:** When installing an ANSI Z21.11.2 ventless appliance, the finishing material used for the mantel must be rated at 250°F or greater.

BTU input of a gas appliance installed in fireplace should be rated less than 100,000 BTU/Hr.

Gas pipe installation is intended for connection to a decorative gas appliance only when (1.) incorporating an automatic shutoff device and (2.) complying with the Standard for Decorative Gas Appliances for Installation in Vented Fireplaces (ANSI Z21.60) or CSA draft requirements for Gas-Fired Log Lighters for Woodburning Fireplaces (Draft No. 4, August 1993).

Decorative gas appliance should be installed in accordance with the National Fuel Gas Code, ANSI Z223.1/ NFPA 54 (latest edition).



**CAUTION: WHEN USING DECORATIVE GAS APPLIANCE, FLUE DAMPER MUST BE SET IN FULLY OPEN POSITION. IF YOU HAVE GLASS DOORS ON THE FIREPLACE, THEY MUST ALSO BE FULLY OPENED.**



**WARNING: DO NOT OPERATE AN UNVENTED GAS LOG SET IN THIS FIREPLACE WITH THE CHIMNEY REMOVED.**



**WARNING: WHEN INSTALLING AN UNVENTED GAS LOG SET, THE CFM CORPORATION MODEL AH3244BK OR AH3244PB 4" ADJUSTABLE HOOD MUST BE USED.**

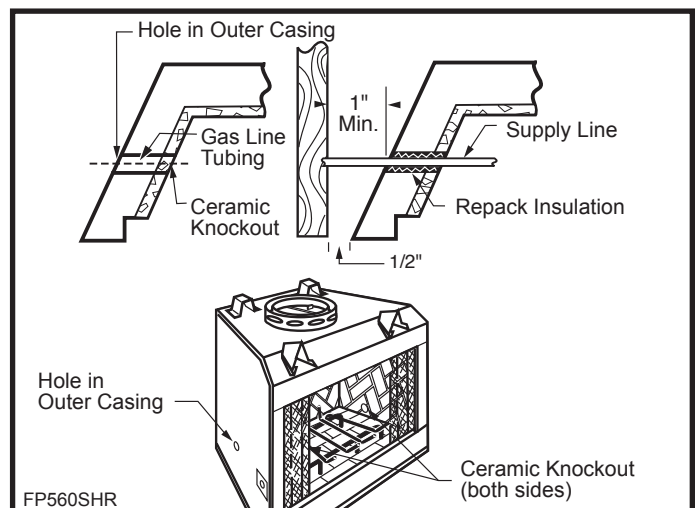
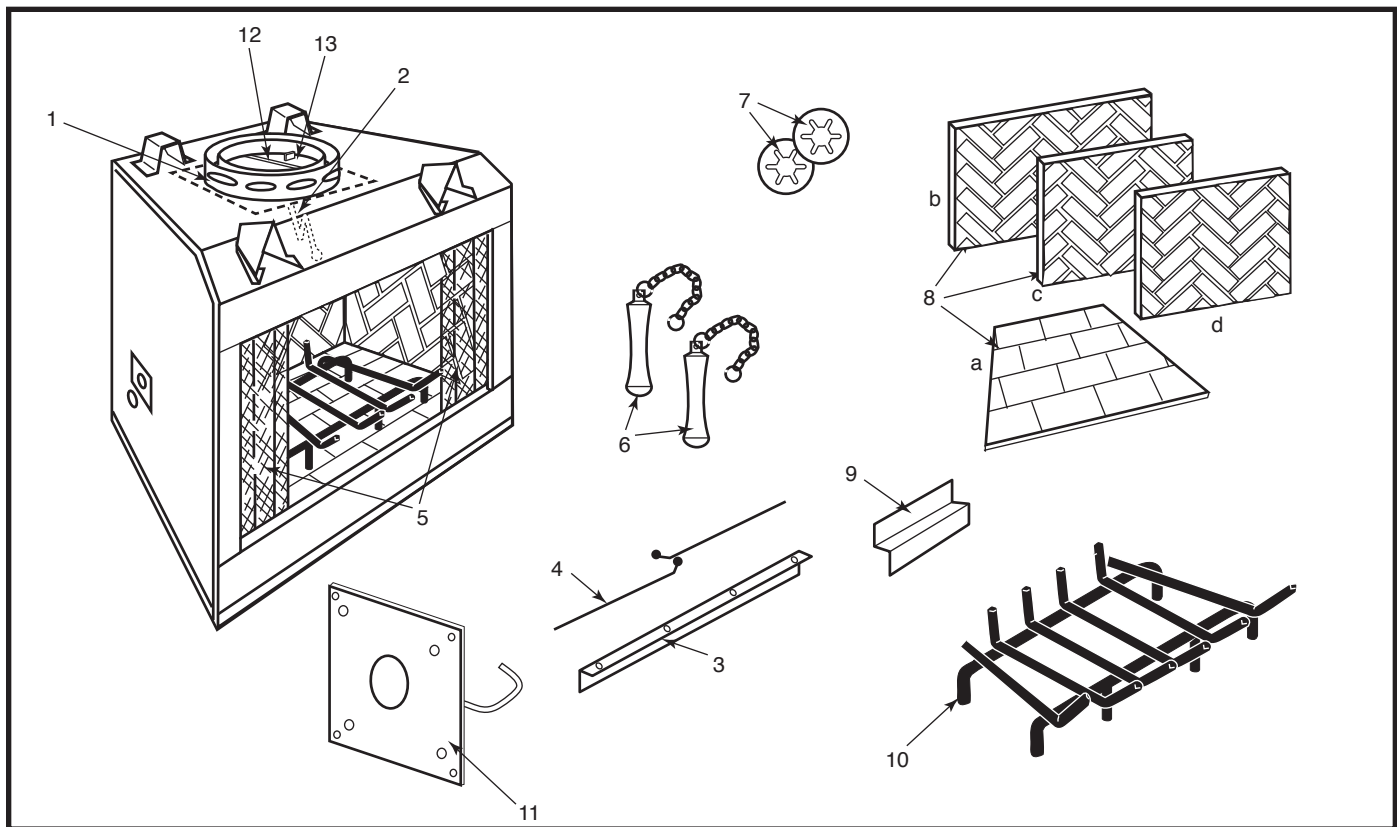

Fig. 36 Gas line access.

If installing an unvented gas log set, refer to statement below:

Only unvented gas log sets which have been found to comply with the Standard for Unvented Room Heaters, ANSI Z21.11.2, are to be installed in this fireplace.



CFM Corporation reserves the right to make changes in design, materials, specifications, prices and discontinue colors and products at any time, without notice.

# SHR36/42A/48/52 Woodburning Fireplace

For units FH30R0, GH40R0, HH30R0, IH10R0

Ref.	Description	SHR36	SHR42A	SHR48	SHR52
1.	Damper Weld Assembly	RP210	RP210	RP210	n/a
2.	Damper Handle	20001418	20001418	20001418	20005322
3.	Screen Rail	20001429	20006021	20001431	20005569
4.	Screen Rod (two per fireplace)	7554181	7554199	20001428	20005790
5.	Screen (two per fireplace)	7554295	20001723	20001723	20005278
6.	Screen Pull (two per fireplace)	5584139	5584139	5584139	5584139
7.	Push Nut (two per fireplace)	7512167	7512167	7512167	7512167
8a.	Firebrick - Hearth	20001272	20005611	20001172	20005303
8b.	Firebrick - Back	20004165	20005610	20004147	20005293
8c.	Firebrick - Left Side	20004166	20005612	20004154	20005302
8d.	Firebrick - Right Side	20004167	20005613	20004148	20005304
9.	Firebrick Retainers (three per fireplace)	20001432	20001432	20001432	20001432
10.	Basket Grate	20004203	20004203	20004311	20005433
11.	O.S.A. Assy.	20003076	20003076	20003076	20005762
12.	Damper Blade Assy	n/a	n/a	n/a	20007536
13.	Pivot Rod	n/a	n/a	n/a	20005772

## Accessories

The following accessories for this appliance are available from your local Majestic Fireplaces distributor. Should you need additional information beyond what your distributor can furnish, contact: CFM Corporation, 410 Admiral Blvd., Mississauga, Ontario, Canada L5T 2N6 Attn: Technical Services.

**CAUTION: This fireplace and chimney assembly is a highly engineered system, and, as such, must be operated only with CFM Corporation approved components. If you use an unapproved component to make any modifications, you may create a possible fire hazard and will void the CFM Corporation warranty. In addition, such action may void the coverage provided by the owner's insurance.**

Accessory	Description	Model No.
Glass Enclosure Kit	Designed to enclose the fireplace opening with glass doors allowing the fire to remain visible. Available in Polished, Brushed Brass, Black and Pewter	36SHGDKDP/BB/BK/S 42SHGDKT/BB/BK/S 48SHGDKDP/BB/BK/S 52SHGDK/BB/BK/S
Outside Air Kit	Provides outside air for fuel combustion in the firebox. This accessory must be installed before fireplace is installed.	AK-MST
Hearth Extension	Located on the floor in front of fireplace to protect the floor from heat, hot embers, ashes, etc.	EH2416
Hearth Patching Kit	Used to patch cracks in hearth.	HPC1
Wall Shield	Used to protect walls adjacent to the fireplace.	SP40
Firestop	Required at each floor level and attic on multi-story installation.	FS2A (straight flue) FS6A (30° inclined flue)
Chimney Support	Used to support the chimney at each 30 feet of vertical height above the hearth and at every 6 feet of inclined chimney run. Each support adds 2½" to chimney length.	11CS (11" flue)

Accessory	Description	Model No.
Contemporary Flashing	Required for contemporary top termination on the roof to prevent rain entry.	8-6-12 (0 to 6/12 pitch) 8-12-12 (6/12 to 12/12 pitch)
Contemporary Chase Top Termination	Used to terminate chimney at the top of a chase. Adapter kit is included, flashing is not included.	SLTCF11
Contemporary Round Top Termination	For use with CFM Corporation Type "11CF" Chimney Systems. Used to terminate chimney on the roof. Flashing not included.	RLTCF11
Extended Round Top	For use with CFM Corporation Type "11CF" Chimney Systems. Used to terminate chimney at top of chase. Adapter kit included. Flashing not included.	RLTCF11L
Chimney Sections	Used to build "11CF" chimney systems.	11" flue 11CF1 (1' long) 11CF18 (1½' long) 11CF3 (3' long) 11CF4 (4' long)
Chimney Elbows	Used to develop 30° offset chimney systems. (Elbows packed 2 per carton - upper and lower elbow set)	11CF30-2 (11" 30° flue)
Top Housing with Upper Baffle	Gives traditional chimney top look using simulated brick in red, tan or white color. Brick pattern is embossed into galvanized steel unit. Roof flashing is included. Appropriate adapter is required. Must be used with upper baffle.	S20BR/BT/BW S20UB (Upper Baffle)
Attic Insulation Shield	Used to prevent insulation from coming in contact with the chimney system. For use with CF11 pipe.	FS2100-HT

# LIMITED WARRANTY & 30 YEAR PROTECTION PLAN

## For MAJESTIC FIREPLACES® PRE-ENGINEERED Fireplace Systems

CFM Corporation warrants its MAJESTIC FIREPLACES® Pre-Engineered Fireplace ("Fireplace") and the CFM Corporation supplied firegrate, glass doors, outside air system, fan motor, and liners to be free from defects in material or workmanship, as follows:

**A. Fireplace and Chimney Components:** (exclusive of CFM Corporation-supplied firegrate, glass doors, outside air system, fan motor, and liners all of which are covered by separate warranties under paragraphs B through D below): At its option for a period of thirty (30) years from the date the Fireplace is installed, CFM Corporation will;

1. For a period of five (5) years from the date the Fireplace is installed, CFM Corporation, at its option, will repair or replace any defective part without charge.
2. Thereafter, through the 10th year after the date the Fireplace is installed, if replacement parts are available, CFM Corporation will provide a replacement for any defective part without charge for the part itself. The consumer must pay for everything else other than the part.
3. Thereafter, through the 30th year after the date the Fireplace is installed, if replacement parts are available, CFM Corporation will provide a replacement for any defective part at a cost to the consumer of CFM Corporation then current list price, FOB CFM Corporation factory.

**B. Firegrate, Glass Doors, Outside Air System:**

For a period of 90 days from the date the Fireplace is installed CFM Corporation, at its option, will provide a replacement for any defective part, without charge for the part itself, FOB CFM Corporation factory, (The consumer must pay for everything else other than the part,).

**C. Fan Motor:**

1. For a period of one (1) year from the date the Fireplace is installed, CFM Corporation, at its option, will repair or replace any defective part without charge.
2. Thereafter, through the 30th year after the date the Fireplace is installed CFM Corporation, at its option, if replacement parts are available, will provide a replacement for any defective part at a cost to the consumer of CFM Corporation then current list price, FOB CFM Corporation factory.

**D. Liners (Refractory or Metal):**

1. For a period of two (2) years from the date the Fireplace is installed, CFM Corporation, at its option, will repair or replace any defective part without charge.
2. Thereafter, through the 30th year after the date the Fireplace is installed CFM Corporation, if replacement parts are available, will provide a replacement for any defective part at a cost to the consumer of CFM Corporation then current list price, FOB CFM Corporation factory.

This warranty is subject to the following conditions and limitations:

1. This warranty is extended only to a Fireplace installed in the continental United States, the state of Alaska and Canada; only if and so long as the Fireplace is installed or serviced by a qualified installer, preferably NFI or WETT (Canada) certified, and according to the installation instructions furnished with

the Fireplace, and operated at all times under normal conditions, use and service according to the operative instructions furnished with the Fireplace, and only if and so long as the Fireplace is not removed from its original installation.

2. This warranty is non-transferrable, and is made to the original owner, provided that the purchase was made through an authorized supplier of the Company.
3. The sole and exclusive remedies for breach of any warranties hereunder shall be for the repair, replacement or provision of a replacement part at CFM Corporation then current list price, FOB CFM Corporation factory, for any defective part as specified in paragraphs A through D.
4. CFM Corporation shall not be liable for damage from any smoking of a MAJESTIC FIREPLACES Pre-Engineered Fireplace System related to environmental geographic conditions (such as, for example, nearby structures or roof peaks, trees, hills, or mountains), inadequate ventilation, or negative air pressure in the place where the Fireplace system is installed, related to any mechanical system (such as, for example, furnaces, fans, air conditioners, clothes dryers, etc.)
5. Except as otherwise expressly specified in paragraphs A through D, NONE OF THESE WARRANTIES COVER, AND CFM CORPORATION SHALL NOT BE RESPONSIBLE FOR, ANY CONSTRUCTION, INSTALLATION, LABOR, TRANSPORTATION OR OTHER COSTS OR EXPENSES ARISING FROM A DEFECTIVE PART, ITS REPAIR OR REPLACEMENT OR OTHERWISE, NOR SHALL CFM CORPORATION IN ANY EVENT BE RESPONSIBLE FOR ANY INDIRECT, INCIDENTAL OR CONSEQUENTIAL DAMAGES EXCEPT TO THE EXTENT REQUIRED BY LAW. Some states do not allow the exclusion or limitation of incidental or consequential damages, so this exclusion or limitation may not apply to you.

NO IMPLIED WARRANTIES, INCLUDING THE IMPLIED WARRANTIES OF MERCHANTABILITY AND FITNESS FOR A PARTICULAR PURPOSE, SHALL REMAIN IN EFFECT AFTER THE EXPIRATION OF THE WARRANTIES SET FORTH IN PARAGRAPHS A THROUGH D. Some states do not allow limitations on how long an implied warranty lasts, so this limitation may not apply to you.

In order to obtain performance of any of the above warranty obligations write to CFM Corporation at this address:

CFM Corporation  
410 Admiral Blvd.  
Mississauga, Ontario, Canada L5T 2N6  
Attention: Director of Warranty Services

Since local building requirements may vary greatly throughout the country, users of CFM Corporation products should determine in advance whether there are any building code restrictions on the use of a specific product. CFM CORPORATION MAKES NO REPRESENTATION OR WARRANTY REGARDING, AND SHALL NOT BE RESPONSIBLE FOR, ANY BUILDING CODE COMPLIANCE.

The foregoing warranties give you specific legal rights and you may also have other rights which vary from state to state.

## **CFM Corporation**

---

410 Admiral Blvd. • Mississauga, Ontario, Canada L5T 2N6  
800-668-5323 • [www.cfmcorp.com](http://www.cfmcorp.com)